

Plotted on: 1/24/2023

SEE SHEET 2 - 3 FOR INDEX OF SHEETS

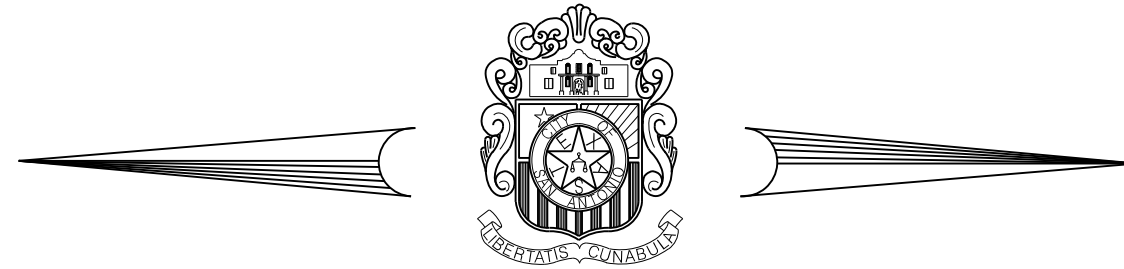

CITY OF SAN ANTONIO PUBLIC WORKS DEPARTMENT DOLOROSA ST RECONSTRUCTION

70% SUBMITTAL

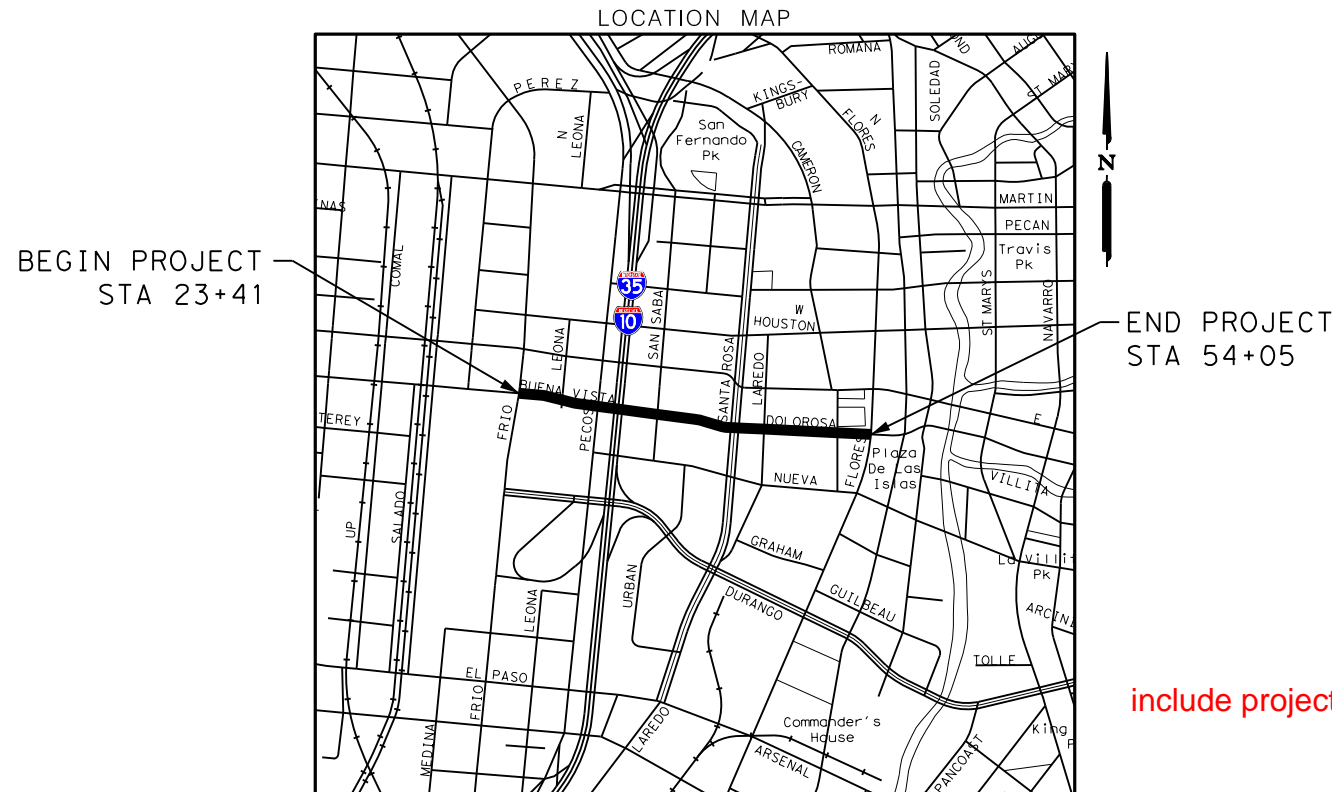

"TDLR INSPECTION REQUIRED"
"TDLR NO.: _____"

DOLOROSA - FRIO TO FLORES
CLASSIFICATION: PRIMARY
ARTERIAL TYPE: A
DESIGN SPEED: 30 MPH
AVERAGE DAILY TRAFFIC (ADT): 6711 VPD

include project length

PLANS PREPARED BY:



SAN ANTONIO | AUSTIN | HOUSTON | FORT WORTH | DALLAS
2000 NW LOOP 410 | SAN ANTONIO, TX 78213 | 210.375.9000
TEXAS ENGINEERING FIRM #470 | TEXAS SURVEYING FIRM #10028800



INTERIM REVIEW
DOCUMENT INCOMPLETE. NOT INTENDED FOR PERMIT, BIDDING OR CONSTRUCTION.
ENGINEER: JOHN A. TYLER
P. E. SERIAL NO: 105193
DATE: 1/24/2023

THROUGH INNOVATION AND DEDICATION, WE BUILD AND MAINTAIN SAN ANTONIO'S INFRASTRUCTURE

Design File name: P:\122\27\03\Design\Civil\General\1222703_pwt\1\lesht.dgn

GENERAL	
1	TITLE SHEET
2-3	INDEX OF SHEETS
4	GENERAL NOTES
5-7	SUPPLEMENTAL GENERAL NOTES
8	PROJECT LAYOUT
9	PROPERTY OWNER INFORMATION
10-11	HORIZONTAL ALIGNMENT DATA
12	SURVEY CONTROL SHEET
13-15	EXISTING TYPICAL
16-19	PROPOSED TYPICAL
20	ESTIMATE & QUANTITY SUMMARY
21	TCP QUANTITY SUMMARY
22	SW3P QUANTITY SUMMARY
23	REMOVAL QUANTITY SUMMARY
24-25	ROADWAY QUANTITY SUMMARY
26	DRAINAGE QUANTITY SUMMARY
27	LANDSCAPE QUANTITY SUMMARY
28	IRRIGATION QUANTITY SUMMARY
29	ELECTRICAL QUANTITY SUMMARY
30-31	TRAFFIC SIGNAL QUANTITY SUMMARY
32	SIGNING & PAVEMENT MARKINGS QUANTITY SUMMARY
33	CONDUIT QUANTITY SUMMARY

TRAFFIC CONTROL PLAN	
34	TRAFFIC CONTROL PLAN GENERAL NOTES
35-36	SEQUENCE OF WORK NARRATIVE
37	ADVANCE WARNING SIGN LAYOUT
38	TRAFFIC CONTROL PLAN PHASING LAYOUT
39	TRAFFIC CONTROL PLAN TYPICAL SECTION PHASE 1 STEP 1
40	TRAFFIC CONTROL PLAN DETOUR LAYOUT PHASE 1
41-43	TRAFFIC CONTROL PHASE PLAN 1 STEP 1
44-45	TRAFFIC CONTROL PLAN TYPICAL SECTIONS PHASE 1 STEP 2
46-50	TRAFFIC CONTROL PLAN PHASE 1 STEP 2
51	TRAFFIC CONTROL PLAN TYPICAL SECTIONS PHASE 1 STEP 3
52-57	TRAFFIC CONTROL PLAN PHASE 1 STEP 3
58-61	TRAFFIC CONTROL PLAN TYPICAL SECTIONS PHASE 2
62-63	TRAFFIC CONTROL PLAN DETOUR LAYOUT PHASE 2
64-69	TRAFFIC CONTROL PLAN PHASE 2
70-72	TRAFFIC CONTROL PLAN INTERSECTION CLOSURE

TRAFFIC CONTROL PLAN STANDARDS	
73-76	*BARRICADE AND CONSTRUCTION STANDARDS
77-86	**BARRICADE AND CONSTRUCTION GENERAL NOTES ((1, 2, 4, 5, 7-12) - 21)
87-88	**TRAFFIC SIGNAL WORK TYPICAL DETAILS (WZ (BTS - 1- BTS-2) - 13)
89	**WORK ZONE SHORT TERM PAVEMENT MARKINGS (WZ (STPM) - 13)
90	**SIGNING FOR UNEVEN LANES (WZ (UL) - 13)
91	**TRAFFIC CONTROL PLAN (TCP (2-1) - 18)
92	**TRAFFIC CONTROL PLAN (TCP (2-2) - 18)
93	**TRAFFIC CONTROL PLAN (TCP (2-3) - 18)
94	**TRAFFIC CONTROL PLAN (TCP (2-4) - 18)
95	**TRAFFIC CONTROL PLAN (TCP (2-5) - 18)
96	**TRAFFIC CONTROL PLAN (TCP (3-1) - 13)
97	**TRAFFIC CONTROL PLAN (TCP (3-4) - 13)

ROADWAY PLANS	
98-105	UTILITY LAYOUT
106-113	REMOVAL LAYOUTS
114-121	ROADWAY PLAN & PROFILE
122-129	ROADWAY SUPPLEMENTAL DETAILS
130-137	INTERSECTION LAYOUTS
138-139	BRIDGE SIDEWALK EXTENSION
140-143	ROADWAY DETAILS
144	PARKING BAY DETAILS
145	LOADING BAY DETAILS
146-147	DRIVEWAY DETAILS
148-149	TRANSIT STOP DETAILS
150-260	CROSS SECTIONS

ROADWAY STANDARDS	
261	*CONSTRUCTION STANDARDS
262-265	**PEDESTRIAN FACILITIES CURB RAMPS (PED - 18)
266	**METAL BEAM GUARD FENCE DOWNSTREAM ANCHOR TERMINAL (GF (31) DAT - 19)
267	**METAL BEAM GUARD FENCE RAIL HEIGHT ADJUSTMENT (RAIL - ADJ (A) - 19)
268-269	**CONTINUOUSLY REINFORCED CONCRETE PAVEMENT (CRCP (1) - 20)
270	**CONCRETE PAVING DETAILS JOINT SEALS (JS - 14)
271-273	**PEDESTRIAN HANDRAILS DETAILS (PRD - 13)
274	**AMOR CURB SLOT WITH CONCRETE FOUNDATION

DRAINAGE PLANS	
275	MISCELLANEOUS DRAINAGE NOTES
276-279	DRAINAGE AREA MAP
280-282	DRAINAGE COMPUTATIONS
283-290	STORM DRAIN LAYOUT
291	STORM DRAIN LATERALS

DRAINAGE STANDARDS	
292	DRAINAGE DETAILS
293	CONCRETE PIPE COLLAR AND CONNECTION DETAIL
294	*PIPE BEDDING & MISCELLANEOUS DRAINAGE DETAILS
295-297	*TYPE "C" INLET (TYPE I & II) & INLET EXTENSION STANDARD
298	*4'x4'x4' JUNCTION BOX STANDARD
299-300	**PRECAST CURB INLET UNDER ROADWAY STANDARD
301-302	**PRECAST SLAB LID
303	**PRECAST AREA ZONE DRAIN STANDARD
304	**CURB AND GUTTER TRANSITION DETAILS FOR PCU INLET

SW3P & ENVIRONMENTAL PLANS	
305	STORM WATER POLLUTION GENERAL NOTES
306-307	STORM WATER POLLUTION PREVENTION PLANS (SW3P) NARRATIVE
308-312	SW3P LAYOUTS

SW3P & ENVIRONMENTAL STANDARDS	
313	*TEMP EROSION, SEDIMENT & WATER POLLUTION CONTROL MEASURES 1
314	*CURB INLET SEDIMENT PROTECTION

LANDSCAPING PLAN	
315	LANDSCAPE SCHEDULE AND NOTES
316-331	LANDSCAPE SITE PLAN
332-334	LANDSCAPE SITE DETAILS

IRRIGATION PLANS	
335	IRRIGATION LEGEND
336	IRRIGATION NOTES
337-352	IRRIGATION PLAN
353-357	LANDSCAPE IRRIGATION DETAILS
358	PLANTING SCHEDULE
359	PLANTING DETAILS
360-375	TREE PRESERVATION & PLANTING PLAN
376-377	TREE PRESERVATION DETAILS
378	TREE PRESERVATION INVENTORY

ELECTRICAL PLANS	
379	ELECTRICAL SYMBOLS & ABBREVIATIONS
380	DEMOLITION ELECTRICAL SHEET LAYOUT
381-388	DEMOLITION ELECTRICAL PLANS
389	ELECTRICAL SHEET LAYOUT
390-397	ELECTRICAL PLANS
398	ELECTRICAL SERVICE ONE - LINE DIAGRAM DUAL METER
399	ELECTRICAL DUAL METER ONE - LINE DIAGRAM
400	ELECTRICAL SERVICE ONE - LINE DIAGRAM SINGLE METER
401	ELECTRICAL SINGLE METER ONE-LINE DIAGRAM
402-403	ELECTRICAL PANEL SCHEDULES
404	ELECTRICAL DETAILS
405	LIGHTING FIXTURE SCHEDULE
406	POLE BASE FOUNDATION DETAIL
407-410	PHOTOMETRIC EXHIBIT

TRAFFIC SIGNAL PLANS	
411	TEMP TRAFFIC SIGNAL LAYOUT DOLOROSA / S PECOS-LA TRINIDAD
412	TEMP TRAFFIC SIGNAL LAYOUT DOLOROSA / S SANTA ROSA
413	EXISTING CONDITIONS BUENA VISTA / S FRIO
414	TRAFFIC SIGNAL LAYOUT BUENA VISTA / S FRIO
415	CONDUIT & CONDUCTOR SCHEDULE BUENA VISTA
416	ELEVATION VIEWS BUENA VISTA
417	EXISTING CONDITIONS BUENA VISTA / S LEONA
418	TRAFFIC SIGNAL LAYOUT BUENA VISTA/ LEONA
419	ELEVATION VIEWS S LEONA
420	EXISTING CONDITIONS DOLOROSA / S PECOS-LA TRINIDAD
421	TRAFFIC SIGNAL LAYOUT DOLOROSA / S PECOS-LA TRINIDAD
422	CONDUIT & CONDUCTOR SCHEDULE PECOS-TRINIDAD
423	POLE SCHEDULE & ILSN DETAILS PECOS-TRINIDAD
424	ELEVATION VIEWS PECOS-TRINIDAD
425	EXISTING CONDITIONS DOLOROSA / S SAN SABA
426	TRAFFIC SIGNAL LAYOUT DOLOROSA / S SAN SABA
427	CONDUIT & CONDUCTOR SCHEDULE SAN SABA
428	ELEVATION VIEWS SAN SABA
429	EXISTING CONDITIONS DOLOROSA / MIDBLOCK CROSSING EAST OF S SAN SABA
430	TRAFFIC SIGNAL LAYOUT DOLOROSA / MIDBLOCK CROSSING EAST OF S SAN SABA
431	ELEVATION VIEWS MIDBLOCK EAST OF SAN SABA
432	EXISTING CONDITIONS DOLOROSA / S SANTA ROSA
433	TRAFFIC SIGNAL LAYOUT DOLOROSA / S SANTA ROSA
434	CONDUIT & CONDUCTOR SCHEDULE DOLOROSA / S SANTA ROSA
435	ELEVATION VIEWS SANTA ROSA
436	EXISTING CONDITIONS DOLOROSA / SAN PEDRO CREEK
437	TRAFFIC SIGNAL LAYOUT DOLOROSA / SAN PEDRO CREEK
438	ELEVATION VIEWS SAN PEDRO CREEK
439	EXISTING CONDITIONS DOLOROSA / PLAZA DE ARMAS
440	TRAFFIC SIGNAL LAYOUT DOLOROSA / PLAZA DE ARMAS
441	CONDUIT & CONDUCTOR SCHEDULE PLAZA DE ARMAS
442	POLE SCHEDULE & ILSN DETAILS PLAZA DE ARMAS
443	ELEVATION VIEWS PLAZA DE ARMAS

TRAFFIC SIGNAL STANDARDS	
444-455	**ELECTRICAL DETAILS CONDUITS & NOTES (ED (1) - 14 - ED (12) - 14)
456	**FITTING ASSEMBLY (CFA - 12)
457	**ARM DETAILS (LUM - A - 12)
458	**MAST ARM CONNECTIONS (MA - C - 12)
459	**MAST ARM CONNECTIONS (MA - C (ILSN) - 12)
460	**MAST ARM POLE DETAILS (MA - D - 12)
461	**MAST ARM DAMPING PLATE DETAILS (MA - DPD - 20)
462	**SINGLE MAST ARM ASSEMBLY (SMA - 80 (1) - 12)
463	**SINGLE MAST ARM ASSEMBLY (SMA - 80 (2) - 12)
464	**TRAFFIC SIGNAL HEAD WITH BACKPLATE (TS - BP - 20)
465	**TRAFFIC SIGNAL POLE FOUNDATION (TS - FD - 12)
466	*COSA 332 CABINET
467	*COSA RADAR

SIGNING & PAVEMENT MARKING	
468-472	SIGNING & PAVEMENT MARKING LAYOUTS
473	PAVEMENT MARKING DETAILS

SIGNING, PAVEMENT MARKING & DELINEATION STANDARDS	
474	*GENERAL NOTES AND GROUND MOUNTING
475	*D3 STREET NAME SIGN AND SIGN MOUNTING
476	*GROUND MOUNTED SIGN SIZES
477	*METRO STREET NAME SIGN AND SIGN PLACEMENT
478	*LEFT-TURN "ONLY" AND ARROW SPACING WORKSHEET
479	*STANDARD PAVEMENT MARKINGS (WORDS)
480	*STANDARD PAVEMENT MARKINGS (ARROWS)
481	*RAISED PAVEMENT MARKERS FOR POSITION GUIDANCE
482	*MARKERS, TRAFFIC BUTTONS & JIGGLE BAR TILES
483	*PAVEMENT MARKINGS FOR ACCESSIBLE PARKING
484	*BICYCLE LANE PAVEMENT MARKERS
485	*TYPICAL CROSSWALK DETAILS
486-487	*LEFT-TURN LANE & RIGHT-TURN LANE DESIGN WORKSHEET (1-2)
488-489	*TWO-WAY LEFT-TURN DETAILS (1-2)
490	*CONTRAST AND SHADOW PAVEMENT MARKINGS

* CITY OF SAN ANTONIO STANDARD
 ** TxDOT STANDARD

DESIGN

INTERIM REVIEW	
DOCUMENT INCOMPLETE. NOT INTENDED FOR PERMIT, BIDDING OR CONSTRUCTION.	ENGINEER: <u>STEVEN J. TATE</u>
P. E. SERIAL NO: <u>131443</u>	DATE: <u>1/25/2023</u>

APPROVAL

INTERIM REVIEW	
DOCUMENT INCOMPLETE. NOT INTENDED FOR PERMIT, BIDDING OR CONSTRUCTION.	ENGINEER: <u>JOHN A. TYLER</u>
P. E. SERIAL NO: <u>105193</u>	DATE: <u>1/25/2023</u>

REV. NO.	DATE	DESCRIPTION	BY



SAN ANTONIO | AUSTIN | HOUSTON | FORT WORTH | DALLAS
 2000 NW LOOP 410 | SAN ANTONIO, TX 78213 | 210.375.9000
 TEXAS ENGINEERING FIRM #470 | TEXAS SURVEYING FIRM #10028800



CITY OF SAN ANTONIO
PUBLIC WORKS DEPARTMENT

DOLOROSA

INDEX OF SHEETS

SHEET 1 OF 2

DESIGN	CHECKED	DRAWN	PROJECT NO.	SUBMITTAL	SHEET NO.
ST	JT	JG	23-03763	70%	2

JOINT BID UTILITIES

491-498	CONDUIT LAYOUT
499	CONDUIT SCHEDULES & NOTES
500-502	CONDUIT DETAILS
503-508	CPS ELECTRIC PLANS
509-519	CPS GAS PLANS
520	SAWS SEWER PLANS - OMITTED
521	SAWS WATER PLANS - OMITTED

* CITY OF SAN ANTONIO STANDARD
** TxDOT STANDARD

DESIGN

INTERIM REVIEW

DOCUMENT INCOMPLETE. NOT INTENDED FOR PERMIT, BIDDING OR CONSTRUCTION.
ENGINEER: STEVEN J. TATE
P. E. SERIAL NO: 131443
DATE: 1/25/2023

APPROVAL

INTERIM REVIEW

DOCUMENT INCOMPLETE. NOT INTENDED FOR PERMIT, BIDDING OR CONSTRUCTION.
ENGINEER: JOHN A. TYLER
P. E. SERIAL NO: 105193
DATE: 1/25/2023

REV. NO.	DATE	DESCRIPTION	BY



SAN ANTONIO | AUSTIN | HOUSTON | FORT WORTH | DALLAS
2000 NW LOOP 410 | SAN ANTONIO, TX 78213 | 210.375.9000
TEXAS ENGINEERING FIRM #470 | TEXAS SURVEYING FIRM #10028800



CITY OF SAN ANTONIO
PUBLIC WORKS DEPARTMENT

DOLOROSA

INDEX OF SHEETS

SHEET 2 OF 2

DESIGN	CHECKED	DRAWN	PROJECT NO.	SUBMITTAL	SHEET NO.
ST	JT	JG	23-03763	70%	3

GENERAL NOTES

1. ALL CONSTRUCTION SHALL CONFORM TO THE CITY OF SAN ANTONIO STANDARD SPECIFICATIONS FOR CONSTRUCTION JUNE 2008, OR LATEST.
2. NO EXTRA PAYMENT SHALL BE ALLOWED FOR WORK CALLED FOR ON THE PLANS, BUT NOT INCLUDED IN THE BID PROPOSAL. THIS INCIDENTAL WORK WILL BE REQUIRED AND SHALL BE INCLUDED IN THE PAY ITEM TO WHICH IT RELATES.
3. THE CONTRACTOR SHALL PROVIDE ACCESS FOR THE DELIVERY OF MAIL BY THE U.S. POSTAL SERVICE.
4. THE CONTRACTOR SHALL BE RESPONSIBLE FOR RESTORING TO ITS ORIGINAL OR BETTER CONDITION ANY DAMAGE DONE TO EXISTING FENCES, CONCRETE ISLANDS, STREET PAVING, CURBS, SHRUBS, BUSHES OR DRIVEWAYS. (NO SEPARATE PAY ITEM).
5. IT IS THE CONTRACTOR'S RESPONSIBILITY TO SEE THAT ALL SIGNS AND BARRICADES ARE PROPERLY INSTALLED AND MAINTAINED. ALL LOCATIONS AND DISTANCES WILL BE DECIDED UPON IN THE FIELD BY THE CONTRACTOR, USING THE "TEXAS MANUAL ON UNIFORM TRAFFIC CONTROL DEVICES". THE CITY'S CONSTRUCTION INSPECTOR AND TRAFFIC ENGINEERING REPRESENTATIVE WILL ONLY BE RESPONSIBLE TO INSPECT BARRICADES AND SIGNS. IF, IN THE OPINION OF THE TRAFFIC ENGINEERING REPRESENTATIVE AND THE CONSTRUCTION INSPECTOR, THE BARRICADES AND SIGNS DO NOT CONFORM TO ESTABLISHED STANDARDS OR ARE INCORRECTLY PLACED OR ARE INSUFFICIENT IN QUANTITY TO PROTECT THE GENERAL PUBLIC, THE CONSTRUCTION INSPECTOR SHALL HAVE THE OPTION TO STOP OPERATIONS UNTIL SUCH TIME AS THE CONDITIONS ARE CORRECTED.
6. IF THE NEED ARISES, ADDITIONAL BARRICADES AND DIRECTIONAL DEVICES MAY BE ORDERED BY THE TRAFFIC ENGINEERING REPRESENTATIVE AT THE CONTRACTOR'S EXPENSE.
7. DUE TO FEDERAL REGULATIONS TITLE 49, PART 192.171 C.P.S. MUST MAINTAIN ACCESS TO GAS VALVES AT ALL TIMES. THE CONTRACTOR MUST PROTECT AND WORK AROUND ANY GAS VALVES THAT ARE IN THE PROJECT AREA.
8. CONTRACTOR SHALL NOTIFY THE CITY INSPECTOR TWENTY FOUR (24) HOURS PRIOR TO BACKFILL OF ANY UTILITY TRENCHES TO SCHEDULE FOR DENSITY TEST AS REQUIRED.
9. CONTRACTOR SHALL PRESERVE ALL CONSTRUCTION STAKES, MARKS, ETC. IF ANY ARE DESTROYED OR REMOVED BY THE CONTRACTOR OR HIS EMPLOYEES, THEY SHALL BE REPLACED AT THE CONTRACTOR'S EXPENSE.
10. CONTRACTOR SHALL NOTIFY ALL UTILITY COMPANIES PRIOR TO CONSTRUCTION TO DETERMINE THE LOCATION OF EXISTING UTILITIES. CONTRACTOR SHALL NOTIFY THE FOLLOWING AT LEAST FORTY-EIGHT (48) HOURS PRIOR TO EXCAVATION OPERATION:
 - SAN ANTONIO WATER SYSTEM (SAWS) 233-2010
 - BEXAR METROPOLITAN WATER DISTRICT (BEXAR MET) 354-6538 /357-5741
 - COSA DRAINAGE 207-8052
 - COSA SIGNAL OPERATIONS 207-7720 /207-7765
 - TEXAS STATE WIDE ONE CALL LOCATOR 1-800-344-8377
 - CITY PUBLIC SERVICE ENERGY
 - CHARTER COMMUNICATIONS (SPECTRUM)
 - AT&T
 - MCI
11. THE EXISTENCE AND LOCATION OF UNDERGROUND UTILITIES INDICATED ON THE PLANS ARE TAKEN FROM AVAILABLE RECORDS AND ARE NOT GUARANTEED, BUT SHALL BE INVESTIGATED AND VERIFIED BY THE CONTRACTOR BEFORE STARTING WORK. THE CONTRACTOR SHALL BE HELD RESPONSIBLE FOR ANY DAMAGE TO AND FOR THE MAINTENANCE AND PROTECTION OF THE EXISTING UTILITIES EVEN IF THEY ARE NOT SHOWN ON THE PLANS. LOCATION AND DEPTH OF EXISTING UTILITIES SHOWN HERE ARE APPROXIMATE ONLY. ACTUAL LOCATIONS AND DEPTHS MUST BE VERIFIED BY THE CONTRACTOR PRIOR TO CONSTRUCTION AND THE CONTRACTOR SHALL BE RESPONSIBLE FOR PROTECTION OF SAME DURING CONSTRUCTION.
12. ALL WASTE MATERIAL SHALL BECOME PROPERTY OF THE CONTRACTOR AND SHALL BE HIS SOLE RESPONSIBILITY TO DISPOSE OF THIS MATERIAL OFF THE LIMITS OF THE PROJECT. NO WASTE MATERIAL SHALL BE PLACED IN EXISTING LOWS THAT WILL BLOCK OR ALTER FLOW LIMITS OF EXISTING ARTIFICIAL OR NATURAL DRAINAGE.
13. THE CONTRACTOR SHALL NOT PLACE ANY WASTE MATERIAL IN THE 100-YEAR FLOOD PLAIN WITHOUT FIRST OBTAINING AN APPROVED FLOOD PLAIN DEVELOPMENT PERMIT.
14. THE CONTRACTOR SHALL MAINTAIN ALL ADJOINING STREETS AND TRAVELED ROUTES FREE FROM SPILLED AND /OR TRACKED CONSTRUCTION MATERIALS AND /OR DEBRIS.
15. IF THE CONTRACTOR ENCOUNTERS ANY ARCHAEOLOGICAL DEPOSITS DURING CONSTRUCTION OPERATIONS, THE CONTRACTOR MUST STOP EXCAVATION IMMEDIATELY, CONTACT THE CITY INSPECTOR, AND CALL THE CITY HISTORIC PRESERVATION OFFICE AT 207-7306 OR 207-3327 FOR AN ARCHAEOLOGICAL INVESTIGATION. THE CONTRACTOR CANNOT BEGIN EXCAVATION AGAIN WITHOUT WRITTEN PERMISSION FROM THE CITY.
 - IF MORE THAN THREE (3) DAYS ARE REQUIRED FOR INVESTIGATION (NOT INCLUDING HOLIDAY AND WEEKENDS) AND IF THE CONTRACTOR IS UNABLE TO WORK IN OTHER AREAS, THEN THE CONTRACTOR WILL BE ALLOWED TO NEGOTIATE FOR ADDITIONAL CONSTRUCTION TIME UPON WRITTEN REQUEST WITHIN TEN (10) DAYS AFTER THE FIRST NOTICE TO THE CITY OF ARCHAEOLOGICAL INVESTIGATION FOR EACH EVENT.
 - IF THE TIME REQUIRED FOR INVESTIGATION IS LESS THAN OR EQUAL TO THREE (3) DAYS FOR EACH EVENT, CONTRACT DURATION WILL NOT BE EXTENDED.
16. IF SUSPECTED CONTAMINATION IS ENCOUNTERED DURING CONSTRUCTION OPERATIONS, C.O.S.A. SHALL BE NOTIFIED IMMEDIATELY WHEN CONTAMINATED SOILS AND /OR GROUNDWATER ARE ENCOUNTERED AT LOCATIONS NOT IDENTIFIED IN THE PLANS. THE NOTIFICATION SHOULD INCLUDE THE STATION NUMBER, TYPE OF CONTAMINATED MEDIA, EVIDENCE OF CONTAMINATION AND MEASURES TAKEN TO CONTAIN THE CONTAMINATED MEDIA AND PREVENT PUBLIC ACCESS. THE CONTAMINATED SOIL AND /OR GROUNDWATER SHALL NOT BE REMOVED FROM THE LOCATION WITHOUT PRIOR C.O.S.A. APPROVAL.
 - THE CONTRACTOR MUST STOP THE EXCAVATION IMMEDIATELY AND CONTACT THE C.O.S.A. INSPECTOR. THE CONTRACTOR CANNOT BEGIN EXCAVATION ACTIVITIES WITHOUT WRITTEN PERMISSION FROM THE CITY.
17. CONTRACTOR IS TO INCLUDE A MAILBOX POST BLOCKOUT FOR VACANT LOTS AND ALL RESIDENCES WHICH DO NOT HAVE MAILBOXES AT THE CURB. BLOCKOUTS ARE PROVIDED FOR FUTURE USE BY THE POST OFFICE.

18. CONTRACTOR SHALL NOT REMOVE OR ADJUST ANY VIA FACILITIES. THE CONTRACTOR MUST CONTACT VIA FOURTEEN DAYS PRIOR, FOR THE REMOVAL OF BENCHES, STOP POLES OR ANY OTHER VIA FACILITIES THAT MAY BE PRESENT. PLEASE PROVIDE THIRTY DAYS PRIOR NOTICE FOR SHELTER REMOVAL (TELEPHONE NOS: (210) 362-2155 OR (210) 362-2096). THE CONTRACTOR OR WILL BE LIABLE FOR ANY DAMAGES TO VIA FACILITIES NOT REMOVED BY VIA. THE CONTRACTOR IS REQUIRED TO REPLACE ALL FLATWORK REMOVED OR DAMAGED IN THE COURSE OF EXECUTING THE CONTRACT UNLESS OTHERWISE NOTED BY VIA. THE CONTRACTOR WILL BE RESPONSIBLE FOR PROTECTING VIA FACILITIES IF ADJACENT TO WORK AREA.

TREE PROTECTION AND PRESERVATION GENERAL NOTES

1. NO UTILITY OR STREET EXCAVATION WORK SHALL BEGIN IN AREAS WHERE TREE PRESERVATION AND TREATMENT MEASURES HAVE NOT BEEN COMPLETED AND APPROVED.
2. TREE PROTECTION FENCING SHALL BE REQUIRED. TREE PROTECTION FENCING SHALL BE INSTALLED, MAINTAINED AND REPAIRED BY THE CONTRACTOR DURING SITE CONSTRUCTION. DURING CONSTRUCTION ACTIVITY, AT LEAST A SIX-INCH LAYER OF COARSE MULCH SHALL BE PLACED AND MAINTAINED OVER THE ROOT PROTECTION ZONE (NO SEPARATE PAY ITEM).
3. THE CONTRACTOR SHALL AVOID CUTTING ROOTS LARGER THAN ONE INCH IN DIAMETER WHEN EXCAVATING NEAR EXISTING TREES. EXCAVATION IN THE VICINITY OF TREES SHALL PROCEED WITH CAUTION. THE CONTRACTOR SHALL CONTACT THE CITY INSPECTOR FOR GUIDANCE.
4. ROOTS WILL BE CUT WITH A ROCK SAW OR BY HAND, NOT BY AN EXCAVATOR OR OTHER ROAD CONSTRUCTION EQUIPMENT.
5. ALL CURB AND SIDEWALK WORK SHALL USE ALTERNATIVE CONSTRUCTION METHODS TO MINIMIZE EXTENSIVE ROOT DAMAGE TO TREES (REFER TO DETAILS).
6. EXPOSED ROOTS SHALL BE COVERED AT THE END OF THE DAY USING TECHNIQUES SUCH AS COVERING WITH SOIL, MULCH, OR WET BURLAP.
7. NO EQUIPMENT, VEHICLES OR MATERIALS SHALL OPERATE OR BE STORED WITHIN THE ROOT PROTECTION ZONE OF ANY TREE NEAR THE PROJECT. ROOT PROTECTION ZONE IS 1 FOOT OF RADIUS PER INCH OF TREE'S DIAMETER. A 10-INCH DIAMETER TREE WOULD HAVE A 10 FOOT RADIUS ROOT PROTECTION ZONE AROUND THE TREE. ROOTS OR BRANCHES IN CONFLICT WITH THE CONSTRUCTION SHALL BE CUT CLEANLY ACCORDING TO PROPER PRUNING METHODS. OAK WOUNDS SHALL BE PAINTED OVER WITHIN 30 MINUTES TO PREVENT OAK WILT.
8. SAPLINGS, SHRUBS OR BUSHES TO BE CLEARED FROM THE PROTECTED ROOT ZONE AREA OF A LARGE TREE SHALL BE REMOVED BY HAND AS DESIGNATED BY THE INSPECTOR.
9. NO WIRES, NAILS OR OTHER MATERIAL MAY BE ATTACHED TO PROTECTED TREES.
10. TREES, TREE LIMBS, BUSHES AND SHRUBS LOCATED IN THE CITY STREET OR ALLEY RIGHT-OF-WAY OR PERMANENT EASEMENTS WHICH INTERFERE WITH PROPOSED CONSTRUCTION ACTIVITIES SHALL BE PROPERLY PRUNED FOLLOWING THE ANSIA-300 STANDARDS FOR PRUNING. ALL TREE PRUNING SHALL BE COMPLETED BY A CITY OF SAN ANTONIO TREE MAINTENANCE LICENSED CONTRACTOR (ARTICLE 21-171, CITY CODE) ONLY AFTER APPROVAL FROM THE CAPITAL PROJECTS MANAGEMENT THROUGH THE INSPECTOR.
11. NO EXCESSIVE TREE TRIMMING WILL BE PERMITTED.
12. ALL DEBRIS GENERATED BY THE PRUNING AND TRIMMING OF THE TREES AND /OR BUSHES SHALL BECOME THE PROPERTY OF THE CONTRACTOR AND SHALL BE DISPOSED OF PROPERLY (NO SEPARATE PAY ITEM).
13. TREES MUST BE MAINTAINED IN GOOD HEALTH THROUGHOUT THE CONSTRUCTION PROCESS. MAINTENANCE MAY INCLUDE, BUT NOT LIMITED TO: WATERING THE ROOT PROTECTION ZONE, WASHING FOLIAGE, FERTILIZATION, PRUNING, ADDITIONAL MULCH APPLICATIONS AND OTHER MAINTENANCE AS NEEDED ON THE PROJECT.
14. ANY TREE REMOVAL SHALL BE APPROVED BY THE CITY ARBORIST. (207-0278)
15. TREES WHICH ARE DAMAGED OR LOST DUE TO THE CONTRACTOR'S NEGLIGENCE DURING CONSTRUCTION SHALL BE MITIGATED TO THE CITY'S SATISFACTION.
16. TREE PLANTING FOR MITIGATION OR ENHANCEMENT: ALL PLANTED TREES SHALL BE MAINTAINED IN A HEALTHY CONDITION AT ALL TIMES. THIS INCLUDES IRRIGATION, FERTILIZING, PRUNING AND OTHER MAINTENANCE AS NEEDED ON THE PROJECT. TREES THAT DIE WITHIN TWELVE (12) MONTHS SHALL BE REPLACED WITH A TREE OF EQUAL SIZE AND SPECIES.

ACCESSIBILITY REQUIREMENTS

1. THE CONTRACTOR SHALL PROVIDE AND MAINTAIN VEHICULAR AND PEDESTRIAN ACCESS AT ALL TIMES TO LOCAL RESIDENCES AND BUSINESSES.
2. WHEN THE WORK REQUIRES THE EXCAVATION OF THE STREET AND SIDEWALKS, THE REMOVAL OF THE EXISTING DRIVEWAY APPROACHES AND SIDEWALKS, THE CONTRACTOR SHALL BE RESPONSIBLE FOR PROVIDING TEMPORARY ALL-WEATHER ACCESS TO THE BUSINESSES AND RESIDENCES. THE TEMPORARY DRIVEWAY APPROACHES SHALL BE CONSTRUCTED WITH FLEXIBLE BASE OR GRAVEL MATERIAL AT NO SEPARATE COST TO THE CITY.
3. PRIOR TO INITIATING THE CONSTRUCTION OF NEW DRIVEWAY APPROACHES, THE CONTRACTOR SHALL GIVE ADVANCE WARNING IN PERSON, OR IN WRITING, OF AT LEAST 48 HOURS TO EACH RESIDENCE THAT WILL BE IMMEDIATELY AFFECTED, SO THAT ALTERNATE PLANS MAY BE MADE BY THE RESIDENTS.
4. FOR BUSINESSES WITH MORE THAN ONE DRIVEWAY, AT LEAST ONE DRIVEWAY SHALL REMAIN OPEN WHILE THE OTHER NEW DRIVEWAY APPROACHES ARE CONSTRUCTED. FOR BUSINESSES WITH ONLY ONE DRIVEWAY, THE NEW DRIVEWAY APPROACH SHALL BE CONSTRUCTED IN HALF WIDTHS, UNLESS A TEMPORARY ASPHALT DRIVEWAY IS FIRST INSTALLED AT NO SEPARATE COST TO THE CITY.

REV. NO.	DATE	DESCRIPTION	BY



PAPE-DAWSON ENGINEERS

SAN ANTONIO | AUSTIN | HOUSTON | FORT WORTH | DALLAS
2000 NW LOOP 410 | SAN ANTONIO, TX 78213 | 210.375.9000
TEXAS ENGINEERING FIRM #470 | TEXAS SURVEYING FIRM #10028800



**CITY OF SAN ANTONIO
PUBLIC WORKS DEPARTMENT**

DOLOROSA

GENERAL NOTES

SHEET 1 OF 1

DESIGN	CHECKED	DRAWN	PROJECT NO.	SUBMITTAL	SHEET NO.
ST	JT	JG	23-03763	70%	4

THE FOLLOWING CHANGES ARE MADE TO THE CITY OF SAN ANTONIO'S GENERAL NOTES:

TRAFFIC SIGNAL NOTES

1. PRIOR TO CONSTRUCTION, THE CITY SHALL APPROVE ALL LOCATIONS FOR POLES, CONTROLLER FOUNDATION AND ELECTRICAL SERVICE PEDESTAL. CONTRACTOR SHALL STAKE LOCATIONS BEFORE CONTACTING GOVERNING AGENCY FOR APPROVAL.
2. ALL ELECTRICAL WORK SHALL COMPLY WITH THE NATIONAL ELECTRIC CODE.
3. CONTRACTOR SHALL FURNISH AND MAINTAIN ALL TRAFFIC CONTROL DEVICES, LIGHTING, OR WARNING DEVICES REQUIRED TO COMPLETE THE WORK. ALL CONSTRUCTION SIGNS AND TRAFFIC CONTROL DEVICES SHALL CONFORM TO THE TEXAS MANUAL ON UNIFORM TRAFFIC CONTROL DEVICES.
4. CONTRACTOR SHALL BE RESPONSIBLE FOR ACQUIRING ALL PERMITS, TESTS, APPROVALS AND ACCEPTANCES REQUIRED TO COMPLETE CONSTRUCTION OF THIS PROJECT.
5. THREE (3) COPIES OF EQUIPMENT SUBMITTALS FOR ALL TRAFFIC SIGNAL COMPONENTS SHALL BE SENT TO THE CITY OF SAN ANTONIO. THE ENGINEER AND/OR PROJECT MANAGER SHALL ENSURE THAT MATERIAL COMPLIES WITH THE CITY OF SAN ANTONIO SPECIFICATIONS AND STANDARDS AND THESE PLANS. SUBMITTALS SHALL CONSIST OF THE APPROPRIATE COMBINATION OF CATALOG SHEETS, MATERIAL LISTS, MANUFACTURER'S BROCHURES, TECHNICAL BULLETINS, SPECIFICATIONS, DIAGRAMS, OR PRODUCT SAMPLES NECESSARY TO DESCRIBE A SYSTEM, PRODUCT, OR ITEM. SPECIFIC ITEM NUMBERS AND PRODUCT CODES WILL BE CLEARLY IDENTIFIED WHEN MULTIPLE PRODUCTS ARE LISTED ON THE SAME SHEET.
6. ALL MATERIALS AND CONSTRUCTION PROCEDURES WITHIN THE SCOPE OF THIS PROJECT SHALL CONFORM TO APPLICABLE CITY OF SAN ANTONIO STANDARD SPECIFICATIONS FOR CONSTRUCTION (LATEST EDITION), TEXAS DOT STANDARD SPECIFICATIONS, CITY BUILDING CODE AND REGULATIONS AS WELL AS PROVISIONS APPLICABLE TO THE PROJECT AND OTHER SAFETY CODES AND INSPECTION REQUIREMENTS OF THE FIRE DEPARTMENT.
7. MATERIALS FURNISHED BY THE CONTRACTOR SHALL BE NEW, UN-DEPRECIATED STOCK. ALL EQUIPMENT SHALL BE NEW, UNLESS NOTED OTHERWISE ON THE PLANS.
8. INSTALL GROUND MOUNT SIGNS, STOPLINES AND PAVEMENT MARKINGS AS SHOWN ON THE PLANS.
9. GROUND BOX COVERS SHALL BE POLYMER CONCRETE WITH "TRAFFIC SIGNAL" LEGIBLY IMPRINTED IN 1 INCH LETTERS (MINIMUM HEIGHT).
10. SALVAGEABLE MATERIALS EQUIPMENT SHALL BE DETERMINED BY THE CITY INSPECTOR AND DELIVERED TO THE CITY OF SAN ANTONIO TRAFFIC OPERATIONS FACILITY LOCATED AT 223 SOUTH CHERRY, SAN ANTONIO, TX 78203. THE CONTRACTOR SHALL CONTACT THE CITY SERVICES & SUPPLY SUPERINTENDENT, AT (210) 207-7771 SEVEN (7) DAYS PRIOR TO DELIVERY OF THE SALVAGED MATERIAL. THE CONTRACTOR SHALL BECOME THE OWNER AND DISPOSE OF UNSALVAGED MATERIAL IN ACCORDANCE WITH FEDERAL, STATE, AND LOCAL REGULATION.
11. CONTRACTOR SHALL BE RESPONSIBLE FOR RESTORING TO ORIGINAL CONDITION, OR BETTER, ANY DAMAGE DONE TO EXISTING BUILDINGS, RETAINING WALLS, UTILITIES, FENCES, PAVEMENT, CURBS, TRAFFIC SIGNAL EQUIPMENT, OR DRIVEWAYS (NO SEPARATE PAY ITEM). CONTRACTOR SHALL RESTORE THE CONSTRUCTION AREA TO ORIGINAL CONDITION, OR BETTER, PRIOR TO FINAL INSPECTION.
12. FINAL ADJUSTMENT OF TRAFFIC SIGNAL HEADS (VEHICLE AND PEDESTRIAN), AS REQUIRED BY THE ENGINEER, SHALL BE DONE BY THE CONTRACTOR AND SHALL BE SUBSIDIARY TO FURNISHING AND INSTALLING TRAFFIC SIGNAL HEADS OR SECTIONS.
13. ALL TRAFFIC SIGNAL SECTIONS SHALL BE MADE OF POLYCARBONATE RESIN AND SHALL BE SUPPLIED BY THE SAME MANUFACTURER.

ALL VEHICLE AND PEDESTRIAN SIGNAL FACES SHALL BE COVERED SO THAT THE INDICATION(S) CANNOT BE SEEN FROM THE TIME OF INSTALLATION UNTIL PLACED IN OPERATION.
14. EXISTING TRAFFIC CONTROLS SHALL REMAIN IN OPERATION UNTIL NEW CONTROLS ARE READY. CONTRACTOR SHALL COORDINATE "TURN-ON" OF THE NEW TRAFFIC SIGNAL WITH THE ENGINEER.
15. WHEN NECESSARY TO TURN OFF AN EXISTING SIGNAL, CONTRACTOR SHALL PROVIDE AN OFF-DUTY UNIFORMED POLICE OFFICER TO CONTROL TRAFFIC UNTIL THE TRAFFIC SIGNAL IS BACK IN SATISFACTORY OPERATION.
16. FOR EACH CABLE TERMINATING IN THE CONTROLLER CABINET AN EXTRA 10 FEET LENGTH SHALL BE PROVIDED. ALL CABLES SHALL BE CONTINUOUS WITHOUT SPLICES FROM TERMINAL POINT TO TERMINAL POINT OR AS DIRECTED/ APPROVED BY THE ENGINEER. THE NUMBER OF CONDUCTORS REQUIRED SHALL BE AS SHOWN ON THE PLANS.
17. CONTRACTOR SHALL CONTACT CITY OF SAN ANTONIO INSPECTOR AT (210) 207-4579 A MINIMUM OF SEVEN (7) DAYS PRIOR TO BEGINNING OF CONSTRUCTION.
18. CONTRACTOR SHALL CONTACT THE CITY ENGINEER AT (210) 207-4507 AND THE CITY INSPECTOR AT (210) 227-3954 A MINIMUM OF FOURTEEN (14) DAYS PRIOR TO THE TRAFFIC SIGNAL TURN-ON.
19. CONTRACTOR SHALL PROVIDE RED-LINE MARK-UPS OF CONSTRUCTION WITHIN SEVEN (7) WORKING DAYS OF PROJECT ACCEPTANCE.
20. PRECONSTRUCTION MEETING WITH COSA PERSONNEL WILL BE REQUIRED PRIOR TO CONTRACTOR INITIATING ANY TRAFFIC SIGNAL RELATED WORK.

21. UPON COMPLETION OF THE PROJECT, A RECORD DRAWING ON MYLAR WILL BE REQUIRED.
22. CONTRACTOR SHALL PROVIDE 3M OPTICOM CERTIFIED TECHNICIAN TO RE-INSTALL OPTICOM EQUIPMENT. CONTRACTOR SHALL BE FULLY RESPONSIBLE FOR SET-UP AND INSTALLATION OF OPTICOM EQUIPMENT.
23. CONTRACTOR, AT CONTRACTORS EXPENSE, SHALL FIELD LOCATE AND STAKE THE LOCATION OF POLES, PULLBOXES, CABINETS, AND DETECTORS FOR APPROVAL BY THE ENGINEER PRIOR TO CONSTRUCTION. POLE AND PULL BOX LOCATIONS MAY BE MOVED BY THE ENGINEER PRIOR TO CONSTRUCTION TO ACCOMMODATE FIELD CONDITIONS.
24. FOR ALL PROPOSED MAST ARM POLE ASSEMBLIES, MOUNTING BRACKET ASSEMBLY OPTION "C" (ASTRO-BRACS) AS SHOWN ON THE STATE STANDARD SHEET(S) "SINGLE MAST ARM ASSEMBLIES (SMA)" SHALL BE SUPPLIED BY THE CONTRACTOR. MOUNTING BRACKET ASSEMBLIES (ASTRO-BRACS) SHALL BE SUBSIDIARY TO ITEM 682 "VEHICLES AND PEDESTRIAN SIGNAL HEADS".
25. ALL STEEL POLE ASSEMBLIES AND PEDESTAL POLES FURNISHED BY THE CONTRACTOR SHALL BE FROM THE SAME MANUFACTURER.
26. CONTRACTOR SHALL SUPPLY ORNAMENTAL CAPS IN PLACE OF THE MAST ARM TENON ENDS.
27. EACH POLE FOUNDATION SHALL HAVE ONE ADDITIONAL 2 INCH CONDUIT STUBBED OUT 2 FEET FROM THE FOUNDATION AND CAPPED. FURNISHING OF THIS CONDUIT SHALL BE SUBSIDIARY TO ITEM 308.
28. CONTRACTOR SHALL UNCOVER AND LOCATE ALL MARKED UNDERGROUND FACILITIES PRIOR TO EXCAVATING FOR DRILLED SHAFT FOUNDATIONS.
29. OVERHEAD UTILITIES MAY EXIST ON THE PROPERTY. NO ATTEMPT WAS MADE TO MARK THE OVERHEAD UTILITIES SINCE THEY ARE CLEARLY VISIBLE. THE CONTRACTOR SHALL LOCATE ALL OVERHEAD UTILITIES PRIOR TO BEGINNING CONSTRUCTION. TEXAS LAW, SECTION 752, HEALTH AND SAFETY CODE FORBIDS ALL ACTIVITIES IN WHICH PERSONS OR THINGS MAY COME WITHIN SIX (6) FEET OF LIVE OVERHEAD HIGH VOLTAGE LINES. CONTRACTORS AND OWNERS ARE LEGALLY RESPONSIBLE FOR THE SAFETY OF CONSTRUCTION WORKERS UNDER THIS LAW. THIS LAW CARRIES BOTH CRIMINAL AND CIVIL LIABILITY, TO ARRANGE FOR LINES TO BE TURNED OFF OR MOVED, CONTACT CPS ENERGY AT 978-3500.
30. CONTRACTOR SHALL UNCOVER AND LOCATE ALL MARKED UNDERGROUND FACILITIES PRIOR TO EXCAVATION.
31. THE CITY MUST ISSUE A WRITTEN AUTHORIZATION TO PROCEED WITH CONSTRUCTION.
32. THE CITY SHALL PROVIDE ALL ON-SITE INSPECTION OF CONSTRUCTION AND SHALL BE THE SOLE AUTHORITY TO DETERMINE ADEQUACY OF MATERIALS AND CONSTRUCTION.
33. THE LENGTH OF TIME FOR ANY TRAFFIC SIGNAL DE-ACTIVATION AND RE-ACTIVATION FOR THIS PROJECT WILL BE MINIMIZED. DE-ACTIVATION CAN ONLY OCCUR DURING OFF-PEAK TIME PERIODS TO MINIMIZE TRAFFIC DISRUPTIONS. OFF-DUTY POLICE OFFICERS ARE REQUIRED IF TRAFFIC SIGNAL DE-ACTIVATION REQUIRES MORE THAN 20 MINUTES (NO SEPARATE PAY ITEM).
34. REMOVE EXISTING ELECTRICAL SERVICES, PEDESTAL POLES, STRAIN POLES, MAST ARM POLE ASSEMBLIES, LUMINAIRES, SIGNAL HEADS, CONTROLLERS, CABLES, AND OTHER ACCESSORIES. REMOVE MATERIALS SO THAT DAMAGE DOES NOT OCCUR. REMOVE AND SALVAGE ALL ITEMS SHOWN ON THE PLANS OR AS DIRECTED.
35. REMOVE ALL EXISTING CABLE REGARDLESS OF TYPE OR NUMBER FROM EXISTING CONDUIT. REMOVE EXISTING CONDUIT 24" BELOW GRADE AS IT TURNS UP INTO THE GROUND BOX. COMPLETELY REMOVE THE GROUND BOXES FROM THE PROJECT ENSURING THAT THE CABLE AND CONDUIT HAS BEEN ALREADY REMOVED AND BACKFILL HOLE WITH MATERIAL EQUAL IN COMPOSITION AND DENSITY TO THE SURROUNDING AREA.
36. REMOVE ABANDONED CONCRETE FOUNDATIONS TO A POINT 2 FT. BELOW FINAL GRADE. BACKFILL HOLE WITH MATERIAL EQUAL IN COMPOSITION AND DENSITY TO THE SURROUNDING AREA. REPLACE SURFACING MATERIAL WITH SIMILAR MATERIAL TO AN EQUIVALENT CONDITION.
37. CONTRACTOR SHALL ACCEPT OWNERSHIP OF UNSALVAGEABLE MATERIALS AND DISPOSE OF IN ACCORDANCE WITH FEDERAL, STATE, AND LOCAL REGULATIONS.
38. UPON RECEIPT OF THE ELECTRICAL PERMIT, THE CONTRACTOR SHALL FAX A COPY TO THE CITY OF SAN ANTONIO TRAFFIC SIGNAL CONSTRUCTION SECTION AT (210) 207-7769, ATTN: ADRIAN OLGUIN. THE CONTRACTOR SHALL SUPPLY AND INSTALL THE ADDRESS IN PERMANENT NUMBERS AND LETTERS TO THE STREET SIDE OF THE ENCLOSURE. SAID ADDRESS SHALL ALSO BE RECORDED AND GIVEN TO THE CITY OF SAN ANTONIO INSPECTOR FOR THE CITY'S RECORDS.
39. ALL CONSTRUCTION SHALL CONFORM TO TXDOT STANDARD SPECIFICATIONS FOR CONSTRUCTION AND MAINTENANCE OF HIGHWAYS, STREETS AND BRIDGES, NOVEMBER 2014.
40. ALL POLES, MAST ARMS, LUMINAIRE ARMS, ILSN ARMS, PEDESTRIAN POLES, AND BASES SHALL BE POWDER COATED COLOR "RAL 6012".

BRACING CPS ENERGY POLES

CONTRACTOR WILL BE RESPONSIBLE FOR BRACING CPS ENERGY POLES AND COVERING AND DE-ENERGIZING POWER LINES AS REQUIRED DURING CONSTRUCTION ACTIVITIES.

HOT MIX ASPHALT CONCRETE PAVEMENT

FOR THIS PROJECT, ALL HOT MIX ASPHALT CONCRETE PAVEMENT SHALL MEET THE REQUIREMENTS OF "PRIMARY AND SECONDARY ARTERIALS" STREET CLASSIFICATION AS SHOWN IN CITY OF SAN ANTONIO SPECIFICATION 205, HOT MIX ASPHALT CONCRETE PAVEMENT, INCLUDING COARSE AGGREGATE AND ASPHALT BINDER REQUIREMENTS.

REMOVAL OF EXISTING PAVEMENT MARKINGS AND RAISED PAVEMENT MARKERS

PER COSA SPECIFICATION 533, THE REMOVAL OF CONFLICTING PAVEMENT MARKINGS/MARKERS IS SUBSIDIARY TO THE VARIOUS PAVEMENT MARKING/MARKER PAY ITEMS. NO SEPERATE PAY ITEM FOR PAVEMENT MARKING/MARKER REMOVAL IS INCLUDED.

CONCRETE JOINTING ALIGNMENT

CONTRACTOR SHALL ALIGN EXPANSION AND FORMED JOINTS OF DIFFERENT CONCRETE PAY ITEMS THAT ARE CONNECTED (ROADWAY PAVEMENT, BUS PADS, CURB, SIDEWALK, RETAINING WALLS). SPACING OF EXPANSION JOINTS MAY NEED TO BE ADJUSTED TO BELOW MAXIMUM ALLOWED AND TYPICAL SPACING. NO DIRECT PAYMENT WILL BE MADE FOR ADJUSTMENT OF JOINT LOCATIONS OR PROVIDING EXPANSION JOINTS.

WORKING DAY CHARGES

WORKING DAY CHARGES WILL COMPLY WITH A SIX-DAY WORKWEEK. WORKING DAYS WILL BE CHARGED MONDAY THROUGH SATURDAY SUN UP TO SUN DOWN, EXCLUDING CITY APPROVED HOLIDAYS.



SAN ANTONIO | AUSTIN | HOUSTON | FORT WORTH | DALLAS
2000 NW LOOP 410 | SAN ANTONIO, TX 78213 | 210.375.9000
TEXAS ENGINEERING FIRM #470 | TEXAS SURVEYING FIRM #10028800



CITY OF SAN ANTONIO
PUBLIC WORKS DEPARTMENT

DOLOROSA
**SUPPLEMENTAL
GENERAL NOTES**

DESIGN	CHECKED	DRAWN	PROJECT NO.	SUBMITTAL	SHEET NO.
ST	JT	JG	23-03763	70%	5

SPECIAL EXCAVATION NOTE

1. ALL EXISTING TRENCH BACKFILL IS ASSUMED TO BE HOMOGENOUS AND OF GRANULAR MATERIAL. THE ENGINEER SHALL BE NOTIFIED IN AREAS WHERE TRENCHBACKFILL CONTAINING CONCRETE OR FLOWABLE FILL IS ENCOUNTERED. ENGINEER MUST APPROVE LIMITS OF SPECIAL EXCAVATION PAID FOR UNDER COSA ITEM 104.2 STREET EXCAVATION (SPECIAL), ASSOCIATED WITH EXCAVATION OF NONHOMOGENOUS BACKFILL MATERIAL.

VIA NOTES

1. THE CONTRACTOR SHALL NOT REMOVE ANY VIA FACILITIES.
2. THE CONTRACTOR SHALL CONTACT VIA FOURTEEN DAYS PRIOR FOR THE REMOVAL OF BENCHES, STOP POLES OR ANY OTHER VIA FACILITIES THAT MAY BE PRESENTS.
3. THE CONTRACTOR SHALL CONTACT VIA THIRTY DAYS PRIOR TO SHELTER REMOVAL.
4. THE CONTRACTOR WILL BE LIABLE FOR ANY DAMAGES TO VIA FACILITIES NOT REMOVED BY VIA.
5. THE CONTRACTOR SHALL REPLACE ALL FLATWORK REMOVED OR DAMAGED IN THE COURSE OF EXECUTING THE CONTRACT UNLESS OTHERWISE NOTED BY VIA.
6. THE CONTRACTOR SHALL BE RESPONSIBLE FOR PROTECTING VIA FACILITIES ADJACENT TO WORK AREA.

DRAINAGE NOTES

1. THE EXISTENCE AND LOCATION OF ALL UNDERGROUND UTILITIES AND DRAINAGE STRUCTURES INDICATED IN THE PLANS ARE TAKEN FROM THE BEST RECORDS AVAILABLE AND ARE NOT GUARANTEED TO BE ACCURATE. CONTRACTOR SHALL VERIFY ACTUAL LOCATION PRIOR TO BEGINNING CONSTRUCTION.
2. SHORING OF EXIST POLES SUBSIDIARY TO INLET & MANHOLE ITEMS.
3. INLETS AND MANHOLES TO BE GROUTED TO PROVIDE POSITIVE DRAINAGE, SUBSIDIARY TO INLET & MANHOLE ITEMS.
4. MANHOLE LIDS ARE TO BE BOLTED DOWN AND PLACED AT FINISHED GRADE AND OUTSIDE OF NORMAL WHEEL PATH (CENTER OF LANE).
5. MANUFACTURER TO PROVIDE DESIGN OF NON-STANDARD BOX SIZES AND DETAILS FOR EQUALIZATION OPENINGS. ALL STORM DRAIN SYSTEMS TO BE INSTALLED IN ACCORDANCE WITH COSA ITEM 550 " TRENCH EXCAVATION SAFETY PROTECTION."
6. REFER TO DRAINAGE DETAILS FOR STATION AND OFFSET REFERENCE POINTS.
7. ALL CONNECTIONS BETWEEN STORM DRAINS (BOX/PIPE) AND STRUCTURES (MANHOLES/INLETS/JUNCTIONS) MUST INCLUDE A CONCRETE COLLAR, SEE DETAILS FOR CONCRETE COLLAR.
8. CONTRACTOR MUST ENSURE UNOBSTRUCTED POSITIVE DRAINAGE IS MAINTAINED DURING THE REMOVAL AND CAPPING OF EXISTING STORM DRAINS.
9. ALL INLETS AND MANHOLES SHALL HAVE LOCKING LIDS, SUBSIDIARY TO STRUCTURE (MANHOLES/INLETS/JUNCTIONS). SEE DRAINAGE SHEET DETAILS (CAM LOCK).
10. CONTRACTOR SHALL VERIFY UTILITY LOCATIONS AND CONFLICTS BEFORE ORDERING MATERIALS.
11. PRIOR TO CONSTRUCTION, THE CONTRACTOR SHALL OBTAIN ALL REQUIRED STORM WATER PERMITS, FEES, AND APPROVALS. NO CONSTRUCTION OR FABRICATION SHALL BEGIN UNTIL THE CONTRACTOR HAS RECEIVED AND THOROUGHLY REVIEWED ALL PERMITS REQUIRED FOR CONSTRUCTION IN DRAINAGE EASEMENTS, RIGHT-OF-WAYS, AND FLOODPLAINS.
12. THE CONTRACTOR SHALL NOTIFY STORM WATER ENGINEERING AT LEAST 24 HOURS PRIOR TO THE INSTALLATION OF ANY DRAINAGE FACILITY WITHIN A DRAINAGE EASEMENT OR STREET RIGHT-OF-WAY NOT INDICATED ON THE CONSTRUCTION PLANS.

13. THE CONTRACTOR IS RESPONSIBLE FOR PROTECTING EXISTING DRAINAGE FACILITIES FROM DAMAGE. ANY DAMAGE TO EXISTING DRAINAGE SYSTEMS, WHETHER OR NOT SHOWN ON THE PLANS, SHALL BE THE RESPONSIBILITY OF THE CONTRACTOR TO REPAIR AT HIS EXPENSE. THE CONTRACTOR SHALL NOTIFY STORM WATER ENGINEERING AT 210-207-8052 AS SOON AS CONFLICTS WITH UTILITIES ARE ENCOUNTERED OR ANY DRAINAGE SYSTEM IS DAMAGED DURING CONTRUCTION.
14. CONSTRUCTION SPOILS WILL NOT BE ALLOWED TO BE DEPOSITED ANYWHERE WITHIN A DRAINAGE EASEMENT, RIGHT-OF-WAY OR FLOODPLAIN WITHIN THE LIMITS OF THE PROJECT AND SHALL BE DISPOSED OFFSITE IN COMPLIANCE WITH CURRENT APPLICABLE REGULATIONS.
15. NO STRUCTURE, FENCES, WALLS, LANSCAPING, OR OTHER STRUCTURES THAT IMPEDE DRAINAGE SHALL BE PLACED WITHIN THE LIMITS OF THE DRAINAGE EASEMENTS SHOWN ON THE CONSTRUCTION DOCUMENTS.
16. UPON COMPLETION OF TRENCHING, THE AREA WILL BE BACKFILLED AND COMPACTED TO ITS ORIGINAL CONDITION. TRENCHES/BORE PITS TO BE OPEN AND UNATTENDED LONGER THAN 24 HOURS SHALL BE PROTECTED TO WITHSTAND ALL HYDRODYNAMIC AND HYDROSTATIC FORCES AND PREVENT DOWNSTREAM IMPACTS. TRENCHES/BORE PITS TO BE OPEN LONGER THAN 30 DAYS AFTER STARTING EXCAVATION SHALL BE BACKFILLED WITH A SEMI-PERMANENT REPAIR BACKFILL.
17. IMPROVED SECTIONS OF EARTHEN CHANNELS AND/OR WATERWAYS WILL BE VEGETATED BY SEEDING OR SODDING. EIGHTY-FIVE PERCENT OF THE CHANNEL SURFACE AREA MUST HAVE ESTABLISHED VEGETATION BEFORE THE CITY OF SAN ANTONIO WILL ACCEPT CHANNEL FOR MAINTENANCE.
18. ALL STORM DRAIN CONNECTIONS MUST USE CONCRETE COLLARS, REFER TO DETAILS IN DRAINAGE DETAIL SHEETS.
19. ALL STORM SRAIN JUNCTION BOXES AND INLETS HAVING TWO OR MORE FULL-DEPTH CONSECUTIVE UNITS MUST HAVE MUD SLAB, REFER TO DETAILS IN DRAINAGE DETAIL SHEETS.
20. AT LOCATIONS WHERE EXISTING INLETS ARE TO BE CAPPED, CONTRACTOR MUST REMOVE ANY EXISTING FILTERS OR SCREENS FROM THE INLETS TO AVOID FUTURE CLOGGING. PAYMENT FOR REMOVAL OF FILTER DEVICES SHALL BE SUBSIDIARY TO 307.1 (CONCRETE STRUCTURE MISCELLANEOUS).

TREE PRESERVATION NOTES

1. PRIOR TO START OF WORK, CALL 207-1111 TO SCHEDULE A PRE-CONSTRUCTION & FENCING INSPECTION (PER SECTION 35-477 OF THE UDC, SUBSECTION TREE PERMITS (5)C)
2. FAILURE TO SCHEDULE A FENCING INSPECTION PRIOR TO START OF WORK MAY RESULT IN A STOP WORK ORDER OR A PENALTY OF \$2000.00 OR BOTH.
3. CONTRACTOR IS RESPONSIBLE FOR PROVIDING A LICENSED TREE MAINTENANCE PROFESSIONAL THROUGHOUT THE PROJECT PER CITY OF SAN ANTONIO ORDINANCE ARTICLE VIII SEC. 21-171.
4. 35-523 (P) MUNICIPAL AND UTILITY ENTITIES SHALL OBTAIN A TREE PERMIT BEFORE ANY VEGETATION IS REMOVED OR NEW CONSTRUCTION ACTIVITY TAKES PLACE. SPECIAL ATTENTION WILL BE GIVEN TO THE PRESERVATION OF TREES IN PUBLIC RIGHTS-OF-WAY THAT ARE TO HELP SATISFY THE OBJECTIVES OF THE STREETScape PLANTING STANDARDS OF THIS ARTICLE (SECTION 35-512). THE CITY ARBORIST SHALL APPROVE AN APPLICATION FOR THE REASONABLE REMOVAL OF A PROTECTED TREE IN CONNECTION WITH CONSTRUCTION, MAINTENANCE OR REPAIR OF PUBLIC FACILITIES IN OR ABOVE A PUBLIC STREET, ALLEY, RIGHTS-OF-WAY, EASEMENT OR OTHER PUBLIC LAND.
5. 35-523 (P)(4) THE LOCATION OF ALL IMPROVEMENTS SHALL BE ORIENTATED BY THE APPLICANT, TO THE EXTENT THE APPLICANT DETERMINES POSSIBLE, IN A MANNER WHICH ALLOWS FOR THE PRESERVING OF THE GREATEST NUMBER OF TREES AND IN DOING SO IS ENCOURAGED TO ACQUIRE RIGHTS-OF-WAY IN SUCH A MANNER. APPLICANTS ARE ALSO ENCOURAGED TO PRESERVE TREES TO MEET THE LANDSCAPE AND STREETScape STANDARDS. ALSO, AS THE PARTICULAR SITE CONDITIONS WARRANT, THE APPLICANT SHALL PRESERVE A DIVERSITY OF SPECIES.
6. 35-477 (J) IT SHALL BE THE RESPONSIBILITY OF THE PERMIT HOLDER TO MAINTAIN A COPY OF THE TREE PERMIT, THE DATA AND DRAWINGS REQUIRED BY THIS SECTION AND THE CONDITIONS OF APPROVAL IMPOSED BY THE CITY ARBORIST READILY AVAILABLE AT THE SITE AT ALL TIMES DURING WHICH AUTHORIZED WORK IS IN PROGRESS.

7. 35-523 (K)(5) ALL OFFSITE STAGING, STORAGE, PROJECT TRAILERS, EMPLOYEE PARKING, ETC. ARE REQUIRED TO COMPLY WITH THE TERMS AND CONDITIONS OF THE APPROVED TREE PERMIT.
8. 35-523 (K)(4) BRANCH/ROOT PRUNING & WOUNDED TREES: ALL BROKEN BRANCHES & EXPOSED ROOTS 2" IN DIAMETER OR GREATER OF SIGNIFICANT, HERITAGE OR MITIGATION TREES SHALL BE CUT CLEANLY. FOR OAK SPECIES, IN ORDER TO PREVENT OAK WILT INFECTION, WOUNDS MUST BE PAINTED WITHIN 30 MIN.
9. 21-170 (B) GENERAL REQUIREMENTS: ALL WOUNDS TO THE TRUNK, LIMBS, AND ROOT SYSTEM OF OAK TREES IN THE CITY THAT EXPOSE SAPWOOD SHALL BE PAINTED WITHIN 30 MIN. OF THE WOUND WITH ASPHALTIC, EXTERIOR OIL OR LATEX BASED PAINT.
10. 35-511 (E) A PROTECTIVE BARRIER, BEGINNING AT THE OUTSIDE OF THE DRIPLINE OF THE TREE, TO PROTECT THE ROOT PROTECTION ZONE SHALL BE ERECTED AND MAINTAINED UNTIL CONSTRUCTION IS COMPLETED.
11. 35-523 (K)(2) THE BARRIER SHALL BE IN PLACE BEFORE ANY SITE WORK IS INITIATED AND MAINTAINED THROUGHOUT THE CONSTRUCTION PROCESS.
12. 35-477 (5)(C) A PRE-CONSTRUCTION MEETING IS REQUIRED TO REVIEW PROCEDURES FOR PROTECTION AND MANAGEMENT OF ALL SIGNIFICANT, HERITAGE OR MITIGATION TREES. THIS CAN BE SCHEDULED WITH THE FENCING INSPECTION, 207-1111.
13. PLEASE FORWARD A COPY TO THE CONTRACTOR ON SITE WITH A COPY OF THE PLAT OR PLAN (IF APPLICABLE) FOR POSTING ON SITE. A COPY OF THE APPROVED PERMIT AND PLAN MUST BE ON SITE DURING SITE WORK.



PAPE-DAWSON ENGINEERS

SAN ANTONIO | AUSTIN | HOUSTON | FORT WORTH | DALLAS
2000 NW LOOP 410 | SAN ANTONIO, TX 78213 | 210.375.9000
TEXAS ENGINEERING FIRM #470 | TEXAS SURVEYING FIRM #10028800



CITY OF SAN ANTONIO
PUBLIC WORKS DEPARTMENT

DOLOROSA

**SUPPLEMENTAL
GENERAL NOTES**

SHEET 2 OF 3

DESIGN	CHECKED	DRAWN	PROJECT NO.	SUBMITTAL	SHEET NO.
ST	JT	JG	23-03763	70%	6

Design File name: P:\122\27\03\Design\Civil\General\1222703_supnotes.dgn
 Plotted on: 1/24/2023 4:49:51 PM

ADDITIONAL GENERAL NOTES

1. A COPY OF THE APPROVED PLANS MUST BE ON SITE WHENEVER CONSTRUCTION IS IN PROGRESS.
2. THE CONTRACTOR SHALL OBTAIN ALL PERMITS REQUIRED FOR WORK WITHIN THE PUBLIC RIGHT-OF-WAY.
3. THE CONTRACTOR SHALL ADJUST ALL EXISTING MAINTENANCE HOLE RIMS, DRAINAGE STRUCTURE LIDS, VALVE BOXES, AND UTILITY ACCESS STRUCTURES TO FINISH GRADE WITHIN AREAS AFFECTED BY THE IMPROVEMENTS.
4. THE CONTRACTOR SHALL PROVIDE FOR ALL COMPACTION TESTS REQUIRED BY THE COSA INSPECTOR FOR WORK WITHIN THE PUBLIC RIGHT-OF-WAY.
5. BACKFILL MATERIAL USED IN PUBLIC RIGHT-OF-WAY SHALL MEET COSA STANDARDS SPECIFICATIONS AND SHALL BE APPROVED BY COSA.
6. INSPECTION AND ACCEPTANCE OF ALL WORK IN PUBLIC STREET RIGHT-OF-WAY WILL BE ACCOMPLISHED BY REPRESENTATIVES OF COSA. IT SHALL BE THE CONTRACTOR'S RESPONSIBILITY TO COORDINATE AND SCHEDULE APPROPRIATE INSPECTIONS, ALLOWING PROPER ADVANCE NOTICE. THE INSPECTORS MAY REQUIRE RECONSTRUCTION OF ITEMS THAT DO NOT MEET COSA STANDARDS OR THAT WERE CONSTRUCTED WITHOUT INSPECTION. ANY RECONSTRUCTION SHALL BE AT CONTRACTOR'S EXPENSE.
7. CARE SHALL BE EXERCISED WHEN EXCAVATING NEAR ANY EXISTING UTILITY LINES AND/OR WITHIN TREE CRITICAL ROOT ZONES.
8. THE CONTRACTOR SHALL SUBMIT CONSTRUCTION HAUL ROUTES TO COSA PRIOR TO CONSTRUCTION.

EARTHWORK AND GRADING NOTES

1. NONCOMPLIANCE WITH EROSION CONTROL REQUIREMENTS, WATER QUALITY REQUIREMENTS, AND CLEARING LIMITS MAY RESULT IN REVOCATION OF PROJECT PERMITS, PLAN APPROVAL, AND BOND FORECLOSURES.
2. PRIOR TO ANY WORK INCLUDING GROUND DISTURBANCE, THE CONTRACTOR SHALL CONTACT COSA TO SCHEDULE A PRE-CONSTRUCTION MEETING.
3. PRIOR TO ANY SITE CONSTRUCTION (WHICH INCLUDES CLEARING, DEMOLITION, OR GRADING THE SITE), CLEARING LIMITS SHALL BE LOCATED AND FIELD IDENTIFIED BY THE CONTRACTOR'S SURVEYOR.
4. ALL EARTHWORK SHALL BE PERFORMED IN ACCORDANCE WITH COSA STANDARDS.
5. ALL STRUCTURAL FILLS SHALL BE COMPACTED TO A MINIMUM OF 95% OF MAXIMUM DENSITY BY MODIFIED PROCTOR TEST UNLESS SPECIFICALLY INDICATED OTHERWISE IN THE SPECIFICATIONS.
6. APPROVAL BY COSA OF THE DRAINAGE AND TEMPORARY EROSION CONTROL PLANS DOES NOT INCLUDE APPROVAL OF THE GRADING ACTIVITIES SHOWN THEREIN. GRADING ACTIVITIES WITHIN THE RIGHT-OF-WAY REQUIRES A PERMIT FROM AHJ. GRADING ACTIVITIES ON ADJACENT PROPERTIES REQUIRES WRITTEN APPROVAL BY THE ADJACENT PROPERTY OWNER.
7. MATCH EXISTING GRADES AT EDGE CONDITIONS AND PROVIDE SMOOTH TRANSITION.
8. SLOPE FINISHED SURFACE A MINIMUM OF 2% AWAY FROM THE BUILDING FOR AT LEAST TWO FEET ON ALL SIDES OF THE BUILDING UNLESS NOTED OTHERWISE.
9. COORDINATE FINE GRADING FOR SURFACE DRAINAGE WITH LANDSCAPE INSTALLATION. FINE GRADING FOR SURFACE DRAINAGE SHALL OCCUR PRIOR TO PLANTING AND MULCHING. GRADE TO PROVIDE POSITIVE DRAINAGE AWAY FROM BUILDING AT BOTH SUBGRADE AND FINISH GRADE.

PRE-CONSTRUCTION MEETING

PRIOR TO ANY CONSTRUCTION ACTIVITY, THE CONTRACTOR SHALL SCHEDULE AND ATTEND A PRE-CONSTRUCTION CONFERENCE WITH COSA. THE CONTRACTOR SHALL NOTIFY THE OWNER AND THE OWNER'S PROFESSIONAL ENGINEERING CONSULTANTS OF THE PRE-CONSTRUCTION MEETING TIME AND LOCATION.

ELECTRONIC INFORMATION TRANSFER AGREEMENT (EITA)

A MICROSTATION (DGN) FILE (FOR THE SOLE PURPOSE OF 2D HORIZONTAL LAYOUT) WILL BE PROVIDED TO THE CONTRACTOR AT THE BEGINNING OF THE PROJECT'S CONSTRUCTION. THE MICROSTATION FILE WILL PROVIDE FOR HORIZONTAL LAYOUT OF CIVIL UTILITIES (STORM, SEWER, AND WATER), STRIPING, LANDSCAPING, AND SPOT ELEVATIONS AND/OR PAVING (WALKS, DRIVES, CURBS) SHOWN ON PLAN VIEW OF THE DRAWINGS OF THIS PROJECT. PRIOR TO RELEASE OF MICROSTATION FILE, CONTRACTOR WILL BE REQUIRED TO SIGN AN ELECTRONIC INFORMATION TRANSFER AGREEMENT (EITA) FORM FROM EACH CONSULTANT. PLEASE SUBMIT REQUEST FOR FORM THROUGH THE OWNER'S PROJECT CONTACT ESTABLISHED FOR THE JOB. OWNER'S PROJECT CONTACT WILL THEN NOTIFY CONSULTANT'S PROJECT MANAGER FOR A COPY OF THE EITA FORM. AFTER CONSULTANT HAS RECEIVED THE SIGNED EITA FORM, ALLOW UP TO SEVEN (7) BUSINESS DAYS FOR PREPARATION OF THE FILE. IF DISCREPANCIES ARE OBSERVED BETWEEN THE MICROSTATION FILE PROVIDED AND INFORMATION SHOWN ON THE HARD COPY OF THE CONSTRUCTION DOCUMENTS, NOTIFY PROJECT CONTACT BY SUBMITTING A RFI.



SAN ANTONIO | AUSTIN | HOUSTON | FORT WORTH | DALLAS
 2000 NW LOOP 410 | SAN ANTONIO, TX 78213 | 210.375.9000
 TEXAS ENGINEERING FIRM #470 | TEXAS SURVEYING FIRM #10028800



CITY OF SAN ANTONIO
PUBLIC WORKS DEPARTMENT

DOLOROSA
**SUPPLEMENTAL
 GENERAL NOTES**

SHEET 3 OF 3

DESIGN	CHECKED	DRAWN	PROJECT NO.	SUBMITTAL	SHEET NO.
ST	JT	JG	23-03763	70%	7

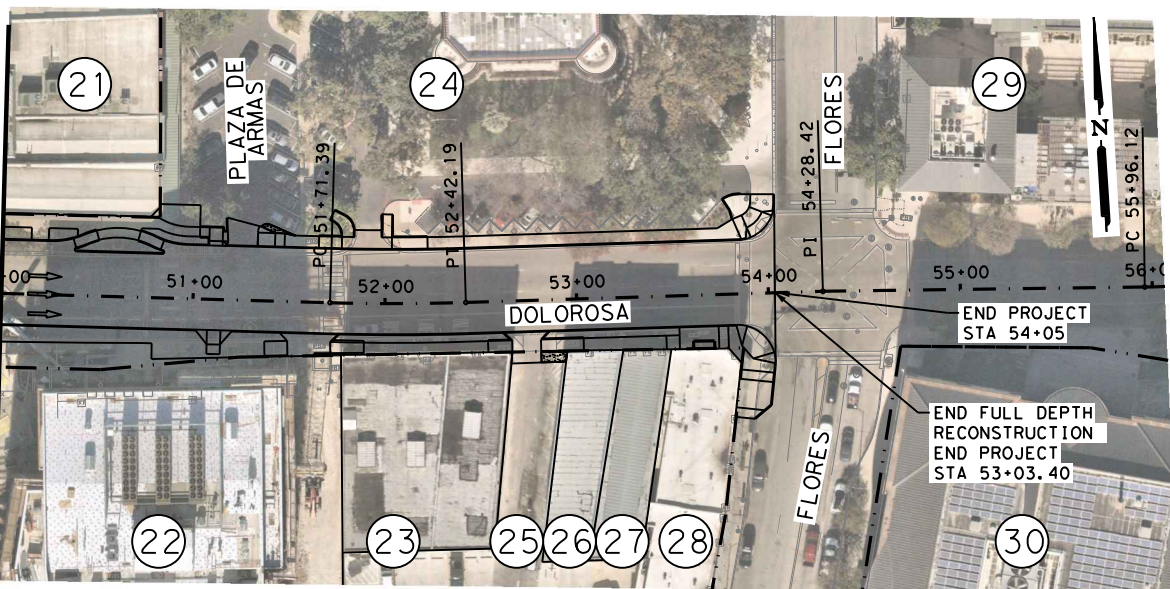
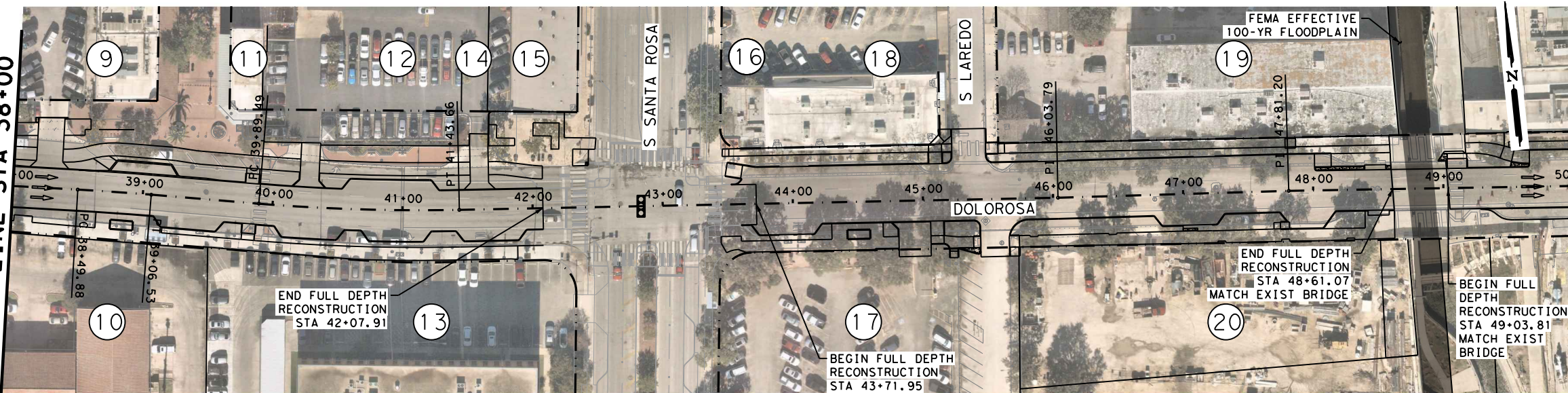
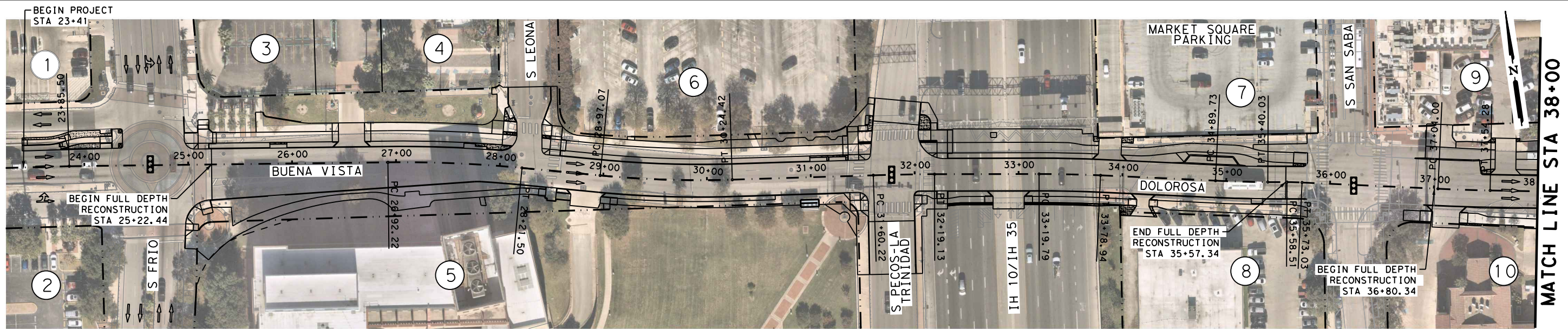

LEGEND

- EXIST ROW
- TRAFFIC FLOW ARROW
- Ⓜ SIGNAL
- Ⓝ PROPERTY OWNER NUMBER SEE SHEET 9

NOTES:
1. SEE HORIZONTAL ALIGNMENT DATA SHEET FOR ALIGNMENT INFORMATION

DESIGN

INTERIM REVIEW
DOCUMENT INCOMPLETE. NOT INTENDED FOR PERMIT, BIDDING OR CONSTRUCTION.
ENGINEER: STEVEN J. TATE
P.E. SERIAL NO: 131443
DATE: 1/25/2023

APPROVAL

INTERIM REVIEW
DOCUMENT INCOMPLETE. NOT INTENDED FOR PERMIT, BIDDING OR CONSTRUCTION.
ENGINEER: JOHN A. TYLER
P.E. SERIAL NO: 105193
DATE: 1/25/2023

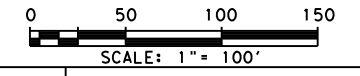

REV. NO.	DATE	DESCRIPTION	BY



PAPE-DAWSON ENGINEERS

SAN ANTONIO | AUSTIN | HOUSTON | FORT WORTH | DALLAS
2000 NW LOOP 410 | SAN ANTONIO, TX 78213 | 210.375.9000
TEXAS ENGINEERING FIRM #470 | TEXAS SURVEYING FIRM #10028800



**CITY OF SAN ANTONIO
PUBLIC WORKS DEPARTMENT**

DOLOROSA

PROJECT LAYOUT

DESIGN	CHECKED	DRAWN	PROJECT NO.	SUBMITTAL	SHEET NO.
ST	JT	JG	23-03763	70%	8

NO.	PROPERTY OWNER NAME	LT/RT	BCAD PROPERTY ID	PROPERTY ADDRESS	OWNER MAILING ADDRESS	LEGAL DESCRIPTION
1	THE CENTER FOR HEALTH CARE SVCS	(LT)	1196013	928 W COMMERCE ST	BEXAR COUNTY BOARD OF TR 3031 W INTERSTATE 10 SAN ANTONIO, TX 78201-5159	NCB 265 BLK 84 LOT 26 COMMERCE ST PROJECT
2	UNIVERSITY OF TEXAS SYSTEM	(RT)	102614	301 S FRIO ST	REAL ESTATE OFFICE 210 W 7TH ST AUSTIN, TX 78701-2903	NCB 268 BLK 90 LOT N IRR 376.63 FT OF 23
3	M T C REAL ESTATE ETAL	(LT)	102916	831 BUENA VISTA ST	800 DOLOROSA STE 204 SAN ANTONIO, TX 78207-4561	NCB 284 BLK 23 LOT 14
4	M T C REAL ESTATE ETAL	(LT)	102912	111 S LEONA ST	800 DOLOROSA STE 204 SAN ANTONIO, TX 78207-4561	NCB 284 BLK 23 LOT 11,12,15 & S 58.6 FT OF 5 & 6, ARB 13
5	UNIVERSITY OF TEXAS SYSTEM	(RT)	103035	501 W CESAR E CHAVEZ BLVD	REAL ESTATE OFFICE 210 W 7TH ST AUSTIN, TX 78701-2903	NCB 302 BLK 18 LOT 26 LEASE (LAND ONLY) VISTA VERDE SOUTH UNIT #2
6	UNIVERSITY OF TEXAS SYSTEM	(LT)	103015	700 COMMERCE PLAZA BLDG	REAL ESTATE OFFICE 210 W 7TH ST AUSTIN, TX 78701-2903	NCB 300 BLK LOT 40
7	CITY OF SAN ANTONIO	(LT)	552140	612 W COMMERCE ST	PO BOX 839966 SAN ANTONIO, TX 78283-3966	NCB 14490 BLK LOT 1
8	SAN SABA OPPORTUNITY FUND LP	(RT)	525041	215 S SAN SABA	215 S SAN SABA #120 SAN ANTONIO, TX 78207	NCB 13416 BLK LOT 6
9	M T C REAL ESTATE	(LT)	104217	218 PRODUCE ROW	800 DOLOROSA STE 204 SAN ANTONIO, TX 78207-4561	NCB 428 BLK 1 LOT 1&2, 3 & 4
10	CAVALIER TEXAS LP	(RT)	525043	900 DOLOROSA	545 E JOHN CARPENTER FRWY IRVING, TX 75062	NCB 13417 BLK LOT 5
11	M T C REAL ESTATE	(LT)	103301	102 CONCHO ST	800 DOLOROSA STE 204 SAN ANTONIO, TX 78207-4561	NCB 340 BLK LOT 12 & NW IRR 3 FT OF LOT 6 (.0014AC)
12	CITY OF SAN ANTONIO	(LT)	103294	807 DOLOROSA	PO BOX 839966 SAN ANTONIO, TX 78283-3966	NCB 340 BLK LOT E IRRG 139.06 FT OF 6
13	800 PAINFUL LP	(RT)	525042	800 DOLOROSA	112 EAST PECAN STE 175 SAN ANTONIO, TX 78205	NCB 13417 BLK LOT 4 & E IRR 91.8 FT OF 3
14	SAN ANTONIO DEVELOPMNT AGENCY	(LT)	103292	116 PRODUCE ROW	1400 S FLORES ST SAN ANTONIO, TX 78204-1617	NCB 340 BLK LOT 5 PUBLIC ALLEY & PEDESTRIAN WALK
15	MTC REAL ESTATE PRTRNSHP	(LT)	103303	803 DOLOROSA	800 DOLOROSA STE 204 SAN ANTONIO, TX 78207-4561	NCB 340 BLK 1 E 69.16 FT OF 3 OR RED H & E 70 FT OF S 20.7 FT OF 1 OR RED D
16	MAJOR SADIE R	(LT)	101584	717 DOLOROSA	4023 FAWN RIDGE DR SAN ANTONIO, TX 78207-3102	NCB 138 LOT 22
17	BOARD OF REGENTS OF THE UNIVERSITY OF TEXAS SYSTEMS	(RT)	525044	702 DOLOROSA	ATTN: EXEC DIR. OF REAL ESTATE 210 W 7TH ST AUSTIN, TX 78701-2903	NCB 13418 BLK LOT 1 E 69.16 FT OF 3 OR RED H & E 70 FT OF S 20.7 FT OF 1 OR RED D
18	GOODWILL INDUSTRIES OF SA	(LT)	101578	703 DOLOROSA	% ROBERT P DUGAS 406 W COMMERCE ST SAN ANTONIO, TX 78207-3102	NCB 138 BLK LOT 13 AND 14
19	601 PAINFUL LP	(LT)	102551	601 DOLOROSA	112 E PECAN ST STE 175 SAN ANTONIO, TX 78205-1522	NCB 254 BLK LOT S 113.78 FT OF BLK
20	BOARD OF REGENTS OF THE UNIVERSITY OF TEXAS SYSTEMS	(RT)	1365371	277 W NUEVA	REAL ESTATE OFFICE 210 W 7TH ST AUSTIN, TX 78701-2903	NCB 13418 (BEXAR CO SAN PEDRO CREEK TRACTS), LOT 6
21	CITY OF SAN ANTONIO	(LT)	101355	115 PLAZA DE ARMAS	PO BOX 839966 SAN ANTONIO, TX 78283-3966	NCB 117 BLK LOT A2 THRU A5
22	BOARD OF REGENTS OF THE UNIVERSITY OF TEXAS SYSTEMS	(RT)	101287	506 DOLOROSA	ATTN: EXEC DIR. OF REAL ESTATE 210 W 7TH ST AUSTIN, TX 78701-2903	NCB 111 BLK LOT N IRR 417.42 FT OF 20, N IRR 410.22 FT OF 21 & N IRR 212.32 FT OF 23
23	GRAYSTREET KALLISON LLC	(RT)	101286	416 DOLOROSA	4515 SAN PEDRO AVE. SAN ANTONIO, TX 78212-1410	NCB 111 LOT N 103.3' OF 17 18, & 19
24	CITY OF SAN ANTONIO	(LT)	109766	100 MILITARY PLAZA	PO BOX 839966 SAN ANTONIO, TX 78283-3966	NCB 865 BLK LOT P-100 ARB CITY HALL
25	GRAYSTREET KALLISON LLC	(RT)	101285	410 DOLOROSA	4515 SAN PEDRO AVE. SAN ANTONIO, TX 78212-1410	NCB 111 BLK LOT 16 & S IRR 100 FT OF 15, 16, 17, 18 & 19
26	GRAYSTREET KALLISON LLC	(RT)	101284	408 DOLOROSA	4515 SAN PEDRO AVE. SAN ANTONIO, TX 78212-1410	NCB 111 LOT 14 N 110.2' OF 15
27	GRAYSTREET KALLISON LLC	(RT)	101282	406 DOLOROSA	4515 SAN PEDRO AVE. SAN ANTONIO, TX 78212-1410	NCB 111 BLK LOT 14
28	GRAYSTREET KALLISON LLC	(RT)	101291	101-199 S FLORES ST	4515 SAN PEDRO AVE. SAN ANTONIO, TX 78212-1410	NCB 111 BLK LOT 26 AND 27
29	SAN FERNANDO CATHEDRAL	(LT)	108660	126 E MAIN PLZ	ARCHDIOCESE OF SAN ANTONIO 231 W COMMERCE ST SAN ANTONIO, TX 78205-2787	NCB 765 BLK LOT 1 REFER TO: 00765-000-0012
30	BEXAR COUNTY	(RT)	1135163	100 W NUEVA	PO BOX 839950 SAN ANTONIO, TX 78283-3966	NCB 100 BLK LOT 25 (BEXAR COUNTY JUSTICE CENTER) & P-100 (CLOSED STREET)

REV. NO.	DATE	DESCRIPTION	BY



PAPE-DAWSON ENGINEERS

SAN ANTONIO | AUSTIN | HOUSTON | FORT WORTH | DALLAS
2000 NW LOOP 410 | SAN ANTONIO, TX 78213 | 210.375.9000
TEXAS ENGINEERING FIRM #470 | TEXAS SURVEYING FIRM #10028800



CITY OF SAN ANTONIO
PUBLIC WORKS DEPARTMENT

DOLOROSA
PROPERTY OWNER INFORMATION

SHEET 1 OF 1

DESIGN	CHECKED	DRAWN	PROJECT NO.	SUBMITTAL	SHEET NO.
ST	JT	JG	23-03763	70%	9

BLDOLOROSA

Beginning chain BLDOLOROSA description
Feature: Geom_Centerline

Point BLDOLOROSA1 N 13,704,892.14 E 2,125,325.16 Sta 10+00.00

Course from BLDOLOROSA1 to BLDOLOROSA3 S 84° 07' 30.13" E Dist 1,385.50

Point BLDOLOROSA3 N 13,704,750.32 E 2,126,703.38 Sta 23+85.50

Course from BLDOLOROSA3 to PC BLDOLOROSA_5 S 83° 09' 32.97" E Dist 306.73

Curve Data

```

Curve BLDOLOROSA_5
P.I. Station      27+56.92 N      13,704,706.08 E      2,127,072.16
Delta            = 6° 10' 20.22" (RT)
Degree           = 4° 46' 28.73"
Tangent         = 64.70
Length          = 129.27
Radius          = 1,200.00
External        = 1.74
Long Chord     = 129.21
Mid. Ord.      = 1.74
P.C. Station    26+92.22 N      13,704,713.79 E      2,127,007.92
P.T. Station    28+21.50 N      13,704,691.51 E      2,127,135.20
C.C.            N      13,703,522.33 E      2,126,864.99
Back            = S 83° 09' 32.97" E
Ahead           = S 76° 59' 12.74" E
Chord Bear     = S 80° 04' 22.86" E

```

Course from PT BLDOLOROSA_5 to PC BLDOLOROSA_8 S 76° 59' 12.74" E Dist 75.57

Curve Data

```

Curve BLDOLOROSA_8
P.I. Station      29+60.83 N      13,704,660.14 E      2,127,270.96
Delta            = 7° 17' 49.13" (LT)
Degree           = 5° 43' 46.48"
Tangent         = 63.76
Length          = 127.36
Radius          = 1,000.00
External        = 2.03
Long Chord     = 127.27
Mid. Ord.      = 2.03
P.C. Station    28+97.07 N      13,704,674.50 E      2,127,208.83
P.T. Station    30+24.42 N      13,704,653.79 E      2,127,334.40
C.C.            N      13,705,648.81 E      2,127,434.00
Back            = S 76° 59' 12.74" E
Ahead           = S 84° 17' 01.87" E
Chord Bear     = S 80° 38' 07.31" E

```

Course from PT BLDOLOROSA_8 to PC BLDOLOROSA_11 S 84° 17' 01.87" E Dist 135.80

Curve Data

```

Curve BLDOLOROSA_11
P.I. Station      31+89.68 N      13,704,637.33 E      2,127,498.84
Delta            = 1° 41' 14.73" (RT)
Degree           = 2° 51' 53.24"
Tangent         = 29.45
Length          = 58.90
Radius          = 2,000.00
External        = 0.22
Long Chord     = 58.90
Mid. Ord.      = 0.22
P.C. Station    31+60.22 N      13,704,640.26 E      2,127,469.53
P.T. Station    32+19.13 N      13,704,633.53 E      2,127,528.04
C.C.            N      13,702,650.21 E      2,127,270.33
Back            = S 84° 17' 01.87" E
Ahead           = S 82° 35' 47.14" E
Chord Bear     = S 83° 26' 24.51" E

```

Course from PT BLDOLOROSA_11 to PC BLDOLOROSA_14 S 82° 35' 47.14" E Dist 100.67

Curve Data

```

Curve BLDOLOROSA_14
P.I. Station      33+49.37 N      13,704,616.75 E      2,127,657.21
Delta            = 2° 47' 13.56" (RT)
Degree           = 4° 42' 42.57"
Tangent         = 29.58
Length          = 59.15
Radius          = 1,216.00
External        = 0.36
Long Chord     = 59.15
Mid. Ord.      = 0.36
P.C. Station    33+19.79 N      13,704,620.56 E      2,127,627.87
P.T. Station    33+78.94 N      13,704,611.51 E      2,127,686.32
C.C.            N      13,703,414.70 E      2,127,471.18
Back            = S 82° 35' 47.14" E
Ahead           = S 79° 48' 33.58" E
Chord Bear     = S 81° 12' 10.36" E

```

Course from PT BLDOLOROSA_14 to PC BLDOLOROSA_17 S 79° 48' 33.58" E Dist 110.79

Curve Data

```

Curve BLDOLOROSA_17
P.I. Station      35+14.89 N      13,704,587.46 E      2,127,820.12
Delta            = 2° 24' 05.52" (LT)
Degree           = 4° 46' 28.73"
Tangent         = 25.15
Length          = 50.30
Radius          = 1,200.00
External        = 0.26
Long Chord     = 50.29
Mid. Ord.      = 0.26
P.C. Station    34+89.73 N      13,704,591.91 E      2,127,795.36
P.T. Station    35+40.03 N      13,704,584.05 E      2,127,845.04
C.C.            N      13,705,772.98 E      2,128,007.67
Back            = S 79° 48' 33.58" E
Ahead           = S 82° 12' 39.10" E
Chord Bear     = S 81° 00' 36.34" E

```

Course from PT BLDOLOROSA_17 to PC BLDOLOROSA_20 S 82° 12' 39.10" E Dist 18.48

Curve Data

```

Curve BLDOLOROSA_20
P.I. Station      35+65.77 N      13,704,580.57 E      2,127,870.54
Delta            = 2° 22' 40.83" (RT)
Degree           = 16° 22' 12.80"
Tangent         = 7.26
Length          = 14.53
Radius          = 350.00
External        = 0.08
Long Chord     = 14.53
Mid. Ord.      = 0.08
P.C. Station    35+58.51 N      13,704,581.55 E      2,127,863.34
P.T. Station    35+73.03 N      13,704,579.28 E      2,127,877.69
C.C.            N      13,704,234.78 E      2,127,815.91
Back            = S 82° 12' 39.10" E
Ahead           = S 79° 49' 58.27" E
Chord Bear     = S 81° 01' 18.68" E

```

Course from PT BLDOLOROSA_20 to PC BLDOLOROSA_23 S 79° 49' 58.27" E Dist 130.97

Curve Data

```

Curve BLDOLOROSA_23
P.I. Station      37+29.14 N      13,704,551.73 E      2,128,031.35
Delta            = 1° 36' 00.72" (LT)
Degree           = 3° 10' 59.16"
Tangent         = 25.14
Length          = 50.27
Radius          = 1,800.00
External        = 0.18
Long Chord     = 50.27
Mid. Ord.      = 0.18
P.C. Station    37+04.00 N      13,704,556.16 E      2,128,006.61
P.T. Station    37+54.28 N      13,704,547.98 E      2,128,056.21
C.C.            N      13,706,327.90 E      2,128,324.34
Back            = S 79° 49' 58.27" E
Ahead           = S 81° 25' 58.99" E
Chord Bear     = S 80° 37' 58.63" E

```

Course from PT BLDOLOROSA_23 to PC BLDOLOROSA_26 S 81° 25' 58.99" E Dist 95.60

Curve Data

```

Curve BLDOLOROSA_26
P.I. Station      38+78.21 N      13,704,529.52 E      2,128,178.75
Delta            = 1° 28' 31.65" (RT)
Degree           = 2° 36' 15.67"
Tangent         = 28.33
Length          = 56.65
Radius          = 2,200.00
External        = 0.18
Long Chord     = 56.65
Mid. Ord.      = 0.18
P.C. Station    38+49.88 N      13,704,533.74 E      2,128,150.74
P.T. Station    39+06.53 N      13,704,524.58 E      2,128,206.65
C.C.            N      13,702,358.29 E      2,127,823.02
Back            = S 81° 25' 58.99" E
Ahead           = S 79° 57' 27.34" E
Chord Bear     = S 80° 41' 43.17" E

```

Course from PT BLDOLOROSA_26 to PC BLDOLOROSA_29 S 79° 57' 27.34" E Dist 82.96

DESIGN

INTERIM REVIEW

DOCUMENT INCOMPLETE. NOT INTENDED FOR PERMIT, BIDDING OR CONSTRUCTION.

ENGINEER: STEVEN J. TATE

P.E. SERIAL NO: 131443

DATE: 1/24/2023

APPROVAL

INTERIM REVIEW

DOCUMENT INCOMPLETE. NOT INTENDED FOR PERMIT, BIDDING OR CONSTRUCTION.

ENGINEER: JOHN A. TYLER

P.E. SERIAL NO: 105193

DATE: 1/24/2023

REV. NO.	DATE	DESCRIPTION	BY

PAPE-DAWSON ENGINEERS

SAN ANTONIO | AUSTIN | HOUSTON | FORT WORTH | DALLAS
2000 NW LOOP 410 | SAN ANTONIO, TX 78213 | 210.375.9000
TEXAS ENGINEERING FIRM #470 | TEXAS SURVEYING FIRM #10028800

 **CITY OF SAN ANTONIO**
PUBLIC WORKS DEPARTMENT

DOLOROSA
HORIZONTAL ALIGNMENT DATA

SHEET 1 OF 2

DESIGN	CHECKED	DRAWN	PROJECT NO.	SUBMITTAL	SHEET NO.
ST	JT	JG	23-03763	70%	10

Curve Data

Curve BLDOLOROSA_29
P.I. Station = 40+66.65 N 13,704,496.66 E 2,128,364.31
Delta = 5° 53' 19.57" (LT)
Degree = 3° 49' 10.99"
Tangent = 77.15
Length = 154.17
Radius = 1,500.00
External = 1.98
Long Chord = 154.10
Mid. Ord. = 1.98
P.C. Station = 39+89.49 N 13,704,510.11 E 2,128,288.34
P.T. Station = 41+43.66 N 13,704,491.07 E 2,128,441.26
C.C. = N 13,705,987.13 E 2,128,549.91
Back = S 79° 57' 27.34" E
Ahead = S 85° 50' 46.91" E
Chord Bear = S 82° 54' 07.12" E

Course from PT BLDOLOROSA_29 to BLDOLOROSA32 S 85° 50' 46.91" E Dist 460.13
Point BLDOLOROSA32 N 13,704,457.74 E 2,128,900.18 Sta 46+03.79
Course from BLDOLOROSA32 to BLDOLOROSA34 S 86° 23' 08.80" E Dist 177.41
Point BLDOLOROSA34 N 13,704,446.56 E 2,129,077.24 Sta 47+81.20
Course from BLDOLOROSA34 to PC BLDOLOROSA_36 S 85° 40' 21.40" E Dist 390.19

Curve Data

Curve BLDOLOROSA_36
P.I. Station = 52+06.80 N 13,704,414.45 E 2,129,501.62
Delta = 3° 22' 48.83" (LT)
Degree = 4° 46' 28.73"
Tangent = 35.41
Length = 70.80
Radius = 1,200.00
External = 0.52
Long Chord = 70.79
Mid. Ord. = 0.52
P.C. Station = 51+71.39 N 13,704,417.12 E 2,129,466.31
P.T. Station = 52+42.19 N 13,704,413.86 E 2,129,537.02
C.C. = N 13,705,613.70 E 2,129,556.86
Back = S 85° 40' 21.40" E
Ahead = S 89° 03' 10.23" E
Chord Bear = S 87° 21' 45.81" E

Course from PT BLDOLOROSA_36 to BLDOLOROSA39 S 89° 03' 10.23" E Dist 186.23
Point BLDOLOROSA39 N 13,704,410.78 E 2,129,723.23 Sta 54+28.42
Course from BLDOLOROSA39 to PC BLDOLOROSA_41 S 88° 03' 10.23" E Dist 167.70

Curve Data

Curve BLDOLOROSA_41
P.I. Station = 56+60.35 N 13,704,402.90 E 2,129,955.03
Delta = 20° 47' 50.61" (LT)
Degree = 16° 22' 12.80"
Tangent = 64.23
Length = 127.04
Radius = 350.00
External = 5.84
Long Chord = 126.35
Mid. Ord. = 5.75
P.C. Station = 55+96.12 N 13,704,405.09 E 2,129,890.83
P.T. Station = 57+23.16 N 13,704,423.66 E 2,130,015.81
C.C. = N 13,704,754.88 E 2,129,902.73
Back = S 88° 03' 10.23" E
Ahead = N 71° 08' 59.16" E
Chord Bear = N 81° 32' 54.47" E

Course from PT BLDOLOROSA_41 to PC BLDOLOROSA_44 N 71° 08' 59.16" E Dist 102.48

Curve Data

Curve BLDOLOROSA_44
P.I. Station = 59+27.65 N 13,704,489.72 E 2,130,209.33
Delta = 32° 29' 46.60" (RT)
Degree = 16° 22' 12.80"
Tangent = 102.00
Length = 198.51
Radius = 350.00
External = 14.56
Long Chord = 195.86
Mid. Ord. = 13.98
P.C. Station = 58+25.65 N 13,704,456.77 E 2,130,112.80
P.T. Station = 60+24.16 N 13,704,465.66 E 2,130,308.45
C.C. = N 13,704,125.54 E 2,130,225.88
Back = N 71° 08' 59.16" E
Ahead = S 76° 21' 14.23" E
Chord Bear = N 87° 23' 52.47" E

Course from PT BLDOLOROSA_44 to BLDOLOROSA46 S 76° 21' 14.23" E Dist 359.84
Point BLDOLOROSA46 N 13,704,380.77 E 2,130,658.13 Sta 63+83.99

Ending chain BLDOLOROSA description

BLEONA
Beginning chain BL_LEONA description
Feature: Geom_Secondary

Point 59 N 13,704,689.86 E 2,127,142.36 Sta 100+00.00
Course from 59 to 60 N 7° 09' 53.59" E Dist 89.42
Point 60 N 13,704,778.58 E 2,127,153.52 Sta 100+89.42
Course from 60 to 61 N 6° 15' 56.54" E Dist 120.06
Point 61 N 13,704,897.92 E 2,127,166.62 Sta 102+09.48

Ending chain BL_LEONA description

DESIGN

INTERIM REVIEW

DOCUMENT INCOMPLETE. NOT INTENDED FOR PERMIT, BIDDING OR CONSTRUCTION.
ENGINEER: STEVEN J. TATE
P.E. SERIAL NO: 131443
DATE: 1/24/2023

APPROVAL

INTERIM REVIEW

DOCUMENT INCOMPLETE. NOT INTENDED FOR PERMIT, BIDDING OR CONSTRUCTION.
ENGINEER: JOHN A. TYLER
P.E. SERIAL NO: 105193
DATE: 1/24/2023

REV. NO.	DATE	DESCRIPTION	BY

PAPE-DAWSON ENGINEERS

SAN ANTONIO | AUSTIN | HOUSTON | FORT WORTH | DALLAS
2000 NW LOOP 410 | SAN ANTONIO, TX 78213 | 210.375.9000
TEXAS ENGINEERING FIRM #470 | TEXAS SURVEYING FIRM #10028800

 **CITY OF SAN ANTONIO
PUBLIC WORKS DEPARTMENT**

**DOLOROSA
HORIZONTAL ALIGNMENT
DATA**

SHEET 2 OF 2

DESIGN	CHECKED	DRAWN	PROJECT NO.	SUBMITTAL	SHEET NO.
ST	JT	JG	23-03763	70%	11

Plotted on: 6/7/2022 7:37:11 AM

Design File name: R:\3089_001\Survey\dgn\drawings\map sheets\HVCS\3089_HVCS.dgn

CP-1
 N: 13,704,386.94
 E: 2,129,998.31
 EL: 649.05'
 ALUMINUM CAP SET
 IN CONCRETE



CP-2
 N: 13,704,454.86
 E: 2,128,515.26
 EL: 646.56'
 ALUMINUM CAP SET
 IN CONCRETE



- NOTES:
1. ALL COORDINATES SHOWN ARE BASED ON TEXAS COORDINATE SYSTEM, SOUTH CENTRAL ZONE, NAD 83 (2011 ADJUSTMENT, EPOCH 2010.00).
 2. ALL COORDINATES AND DISTANCES SHOWN ARE SURFACE VALUES AND MAY BE CONVERTED TO GRID BY DIVIDING BY THE SURFACE ADJUSTMENT FACTOR OF 1.00017. UNITS: US SURVEY FEET.
 3. ALL ELEVATIONS SHOWN ARE BASED ON NAVD88 USING GEOID 12B.
 4. HORIZONTAL CONTROL WAS ESTABLISHED USING RTK METHODS CONSTRAINED TO 109 AND 120 AS ESTABLISHED FOR SANTA ROSA - CESAR E. CHAVEZ TO MARTIN PROJECT BY BAIN MEDINA BAIN, INC. IN APRIL 2021.
 5. VERTICAL CONTROL WAS ESTABLISHED BY DIGITAL DIFFERENTIAL LEVELING METHODS CONSTRAINED TO 109 AND 120 AS ESTABLISHED FOR SANTA ROSA - CESAR E. CHAVEZ TO MARTIN PROJECT BY BAIN MEDINA BAIN, INC. IN APRIL 2021.

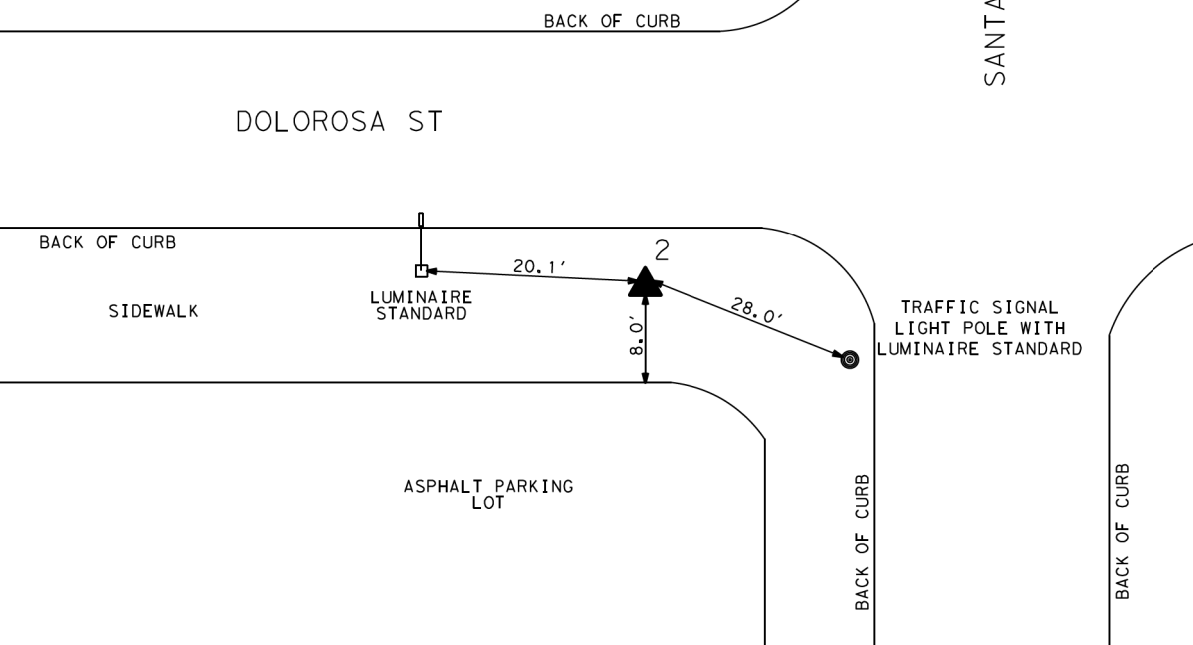
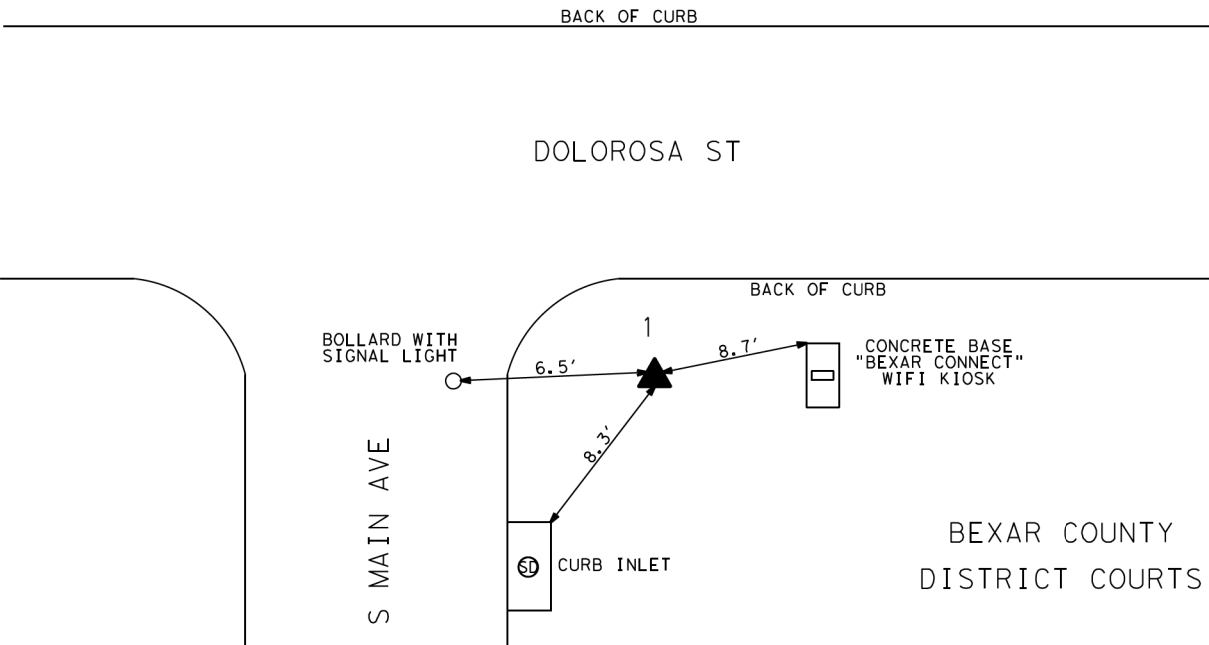

Control point 1 is located at the southeast quadrant of the Dolorosa St and S Main Ave intersection, approximately 6.5 feet east of a bollard post with signal light, 8.3 feet northeast of the northeast corner of a curb inlet junction box, and 8.7 feet west of the northwest corner of a concrete base for a Bexar Connect Wifi kiosk.

Control point 2 is located at the southwest quadrant of the Dolorosa St and Santa Rosa Ave intersection, approximately 8.0 feet north of and perpendicular to the south edge of a concrete sidewalk, 20.1 feet east of a luminaire standard, and 28.0 feet northwest of a traffic signal light pole with a luminaire standard.

CP-3
 N: 13,704,780.87
 E: 2,126,680.08
 EL: 652.94'
 ALUMINUM CAP SET
 IN CONCRETE



THE CENTER FOR
 HEALTH CARE SERVICES

928 W COMMERCE ST
 SAN ANTONIO, TX 78207

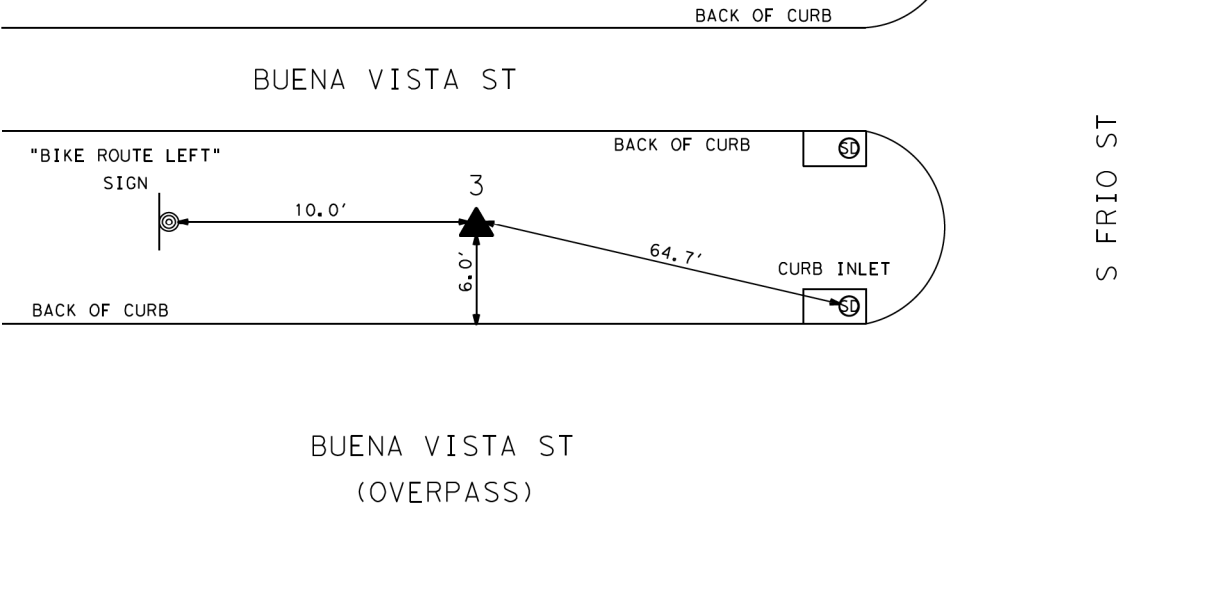

Control point 3 is located in a concrete curb island on the side of Buena Vista St, approximately 6.0 feet north of and perpendicular to the back of curb, 10.0 feet east of a "BIKE ROUTE" sign, and 64.7 feet northwest of a storm sewer manhole.

PRELIMINARY. THIS DOCUMENT SHALL NOT BE RECORDED FOR ANY PURPOSE AND SHALL NOT BE USED OR VIEWED OR RELIED UPON AS A FINAL SURVEY DOCUMENT.

MICHAEL J. VANDERSTAPPEN
 RPLS #6594

DATE: 7/14/2022

NOT TO SCALE

REV. NO.	DATE	DESCRIPTION	BY

VICKREY & ASSOCIATES, LLC.
 CONSULTING ENGINEERS
 CIVIL • ENVIRONMENTAL • SURVEY
 12940 Country Parkway
 San Antonio, TX 78216
 Telephone: (210) 349-3271
 TBPELS #10004100 ©2022

PAPE-DAWSON ENGINEERS
 SAN ANTONIO | AUSTIN | HOUSTON | FORT WORTH | DALLAS
 2000 NW LOOP 410 | SAN ANTONIO, TX 78213 | 210.375.9000
 TEXAS ENGINEERING FIRM #470 | TEXAS SURVEYING FIRM #10028800

**CITY OF SAN ANTONIO
 PUBLIC WORKS DEPARTMENT**

DOLOROSA
 SURVEY CONTROL SHEET
 FRIO STREET TO SOUTH FLORES STREET
 SHEET 1 OF 1

DESIGN	CHECKED	DRAWN	PROJECT NO.	SUBMITTAL	SHEET NO.
DG	MJV	DG	23-03763	70%	12

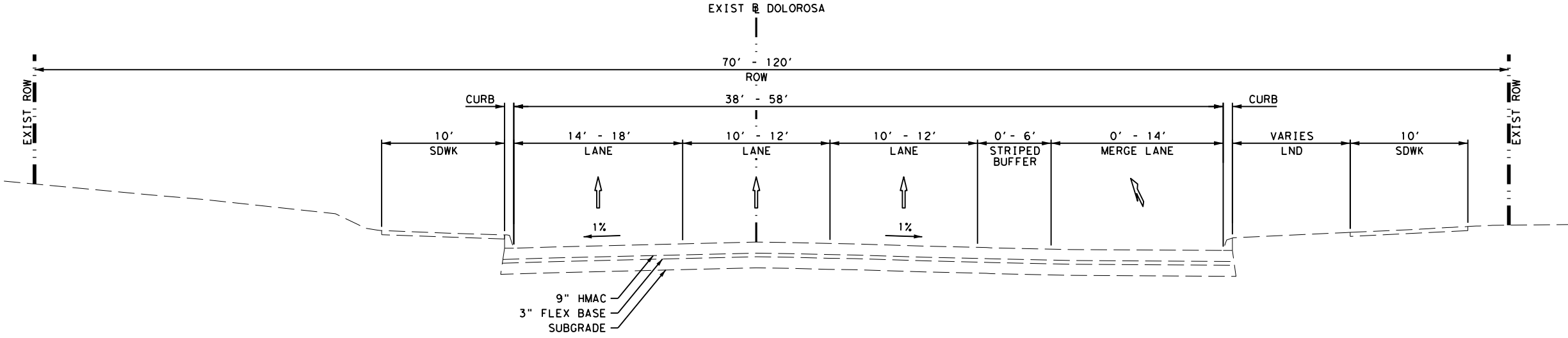

EXISTING TYPICAL SECTION
NTS
STA 25+22 TO STA 32+15

NOTES:

1. LND DESIGNATES LANDSCAPE AREAS.

DESIGN

INTERIM REVIEW
DOCUMENT INCOMPLETE. NOT INTENDED FOR PERMIT, BIDDING OR CONSTRUCTION.
ENGINEER: STEVEN J. TATE
P.E. SERIAL NO: 131443
DATE: 1/24/2023

APPROVAL

INTERIM REVIEW
DOCUMENT INCOMPLETE. NOT INTENDED FOR PERMIT, BIDDING OR CONSTRUCTION.
ENGINEER: JOHN A. TYLER
P.E. SERIAL NO: 105193
DATE: 1/24/2023

NOT TO SCALE

REV. NO.	DATE	DESCRIPTION	BY



SAN ANTONIO | AUSTIN | HOUSTON | FORT WORTH | DALLAS
2000 NW LOOP 410 | SAN ANTONIO, TX 78213 | 210.375.9000
TEXAS ENGINEERING FIRM #470 | TEXAS SURVEYING FIRM #10028800



DOLOROSA
EXISTING TYPICAL

SHEET 1 OF 3

DESIGN	CHECKED	DRAWN	PROJECT NO.	SUBMITTAL	SHEET NO.
ST	JT	JG	23-03763	70%	13

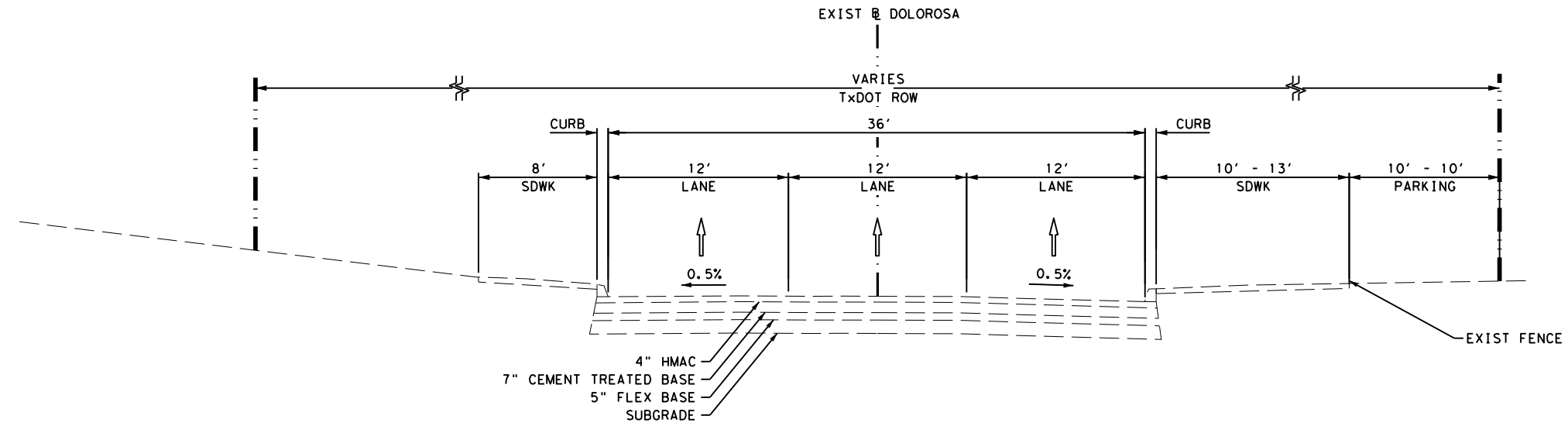

EXISTING TYPICAL SECTION
NTS
STA 32+15 TO STA 34+15

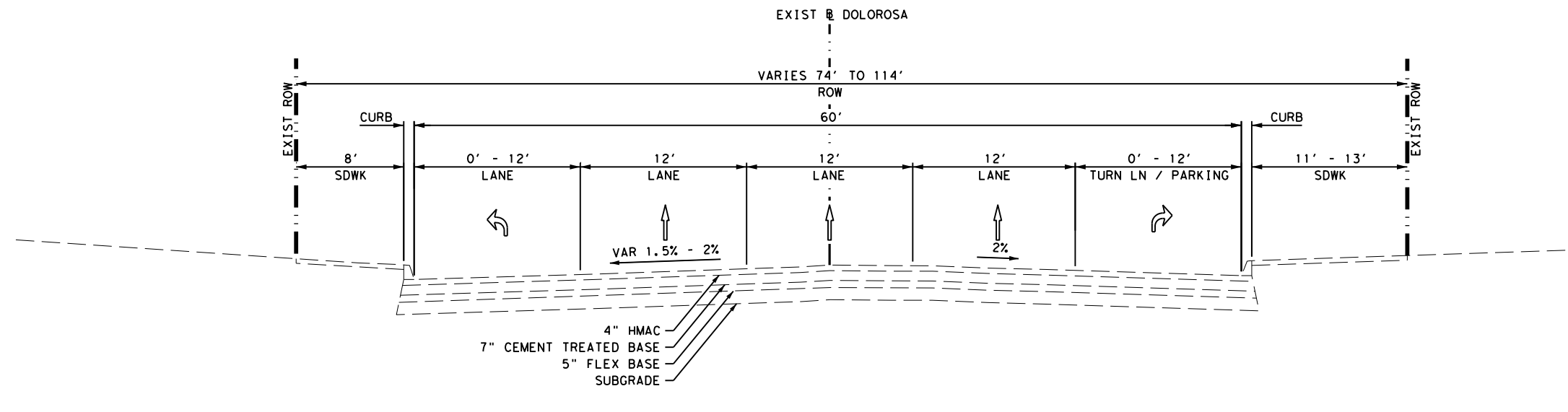

EXISTING TYPICAL SECTION

NTS
STA 34+41 TO STA 43+43

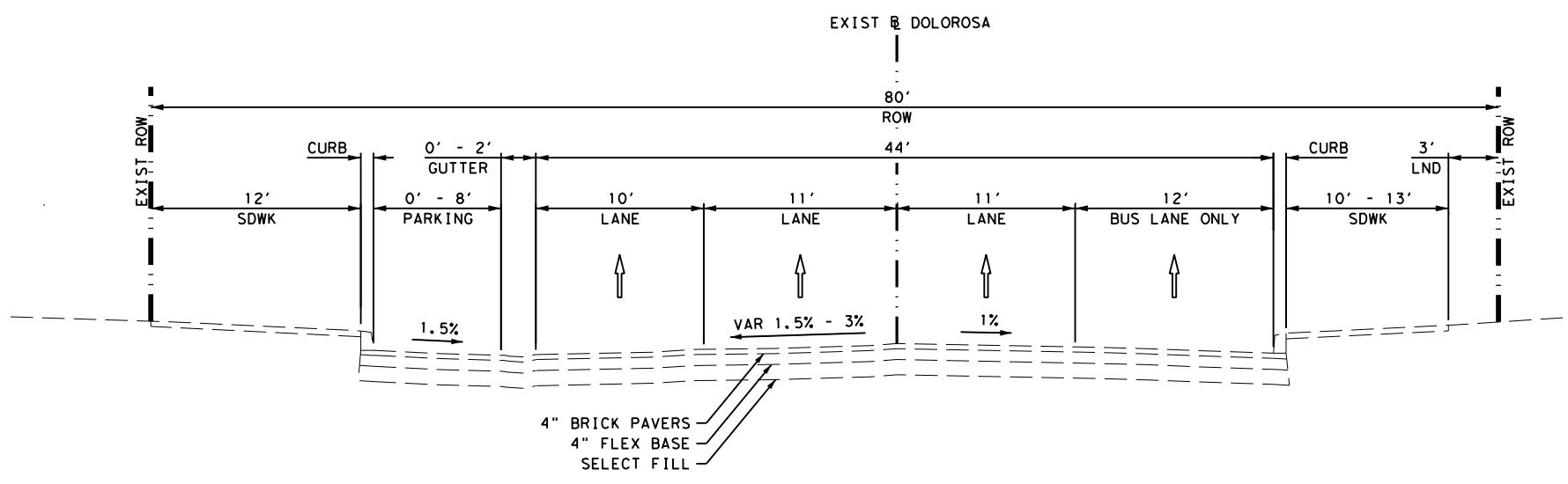

EXISTING TYPICAL SECTION

NTS
STA 43+43 TO STA 48+61

NOTES:

1. LND DESIGNATES LANDSCAPE AREAS.

DESIGN

INTERIM REVIEW
DOCUMENT INCOMPLETE. NOT INTENDED FOR PERMIT, BIDDING OR CONSTRUCTION.
ENGINEER: STEVEN J. TATE
P.E. SERIAL NO: 131443
DATE: 1/24/2023

APPROVAL

INTERIM REVIEW
DOCUMENT INCOMPLETE. NOT INTENDED FOR PERMIT, BIDDING OR CONSTRUCTION.
ENGINEER: JOHN A. TYLER
P.E. SERIAL NO: 105193
DATE: 1/24/2023

NOT TO SCALE

REV. NO.	DATE	DESCRIPTION	BY



SAN ANTONIO | AUSTIN | HOUSTON | FORT WORTH | DALLAS
2000 NW LOOP 410 | SAN ANTONIO, TX 78213 | 210.375.9000
TEXAS ENGINEERING FIRM #470 | TEXAS SURVEYING FIRM #10028800



DOLOROSA

EXISTING TYPICAL

SHEET 2 OF 3

DESIGN	CHECKED	DRAWN	PROJECT NO.	SUBMITTAL	SHEET NO.
ST	JT	JG	23-03763	70%	14

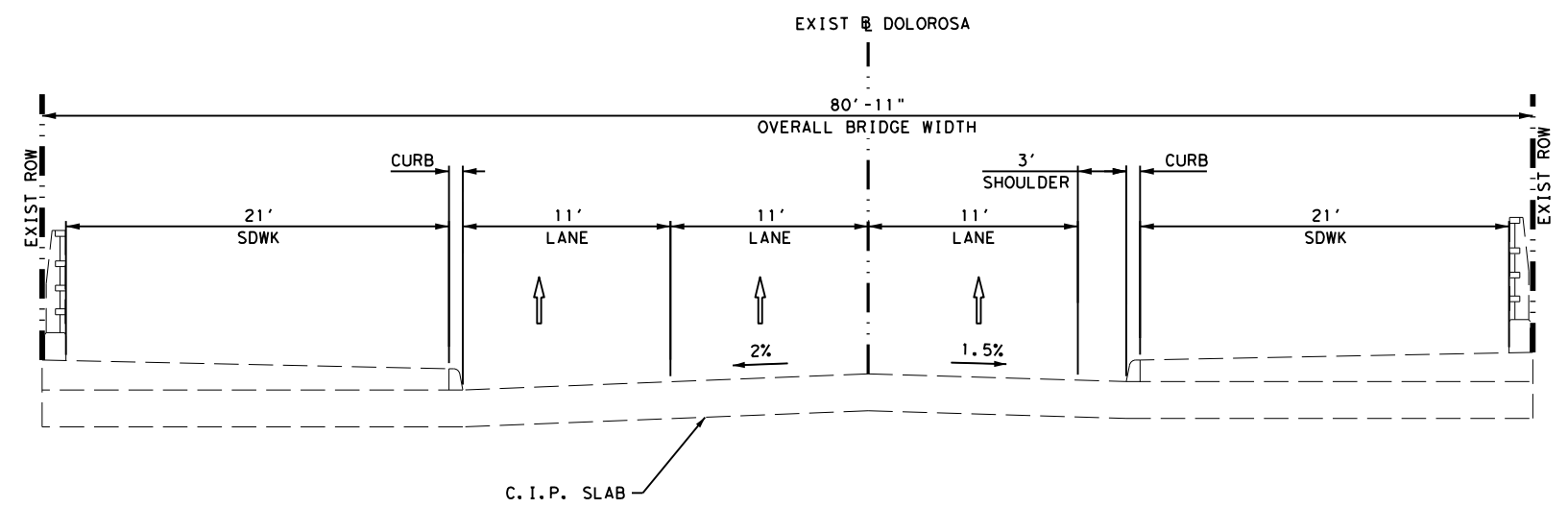

EXISTING TYPICAL SECTION

NTS
STA 48+61 TO STA 49+04

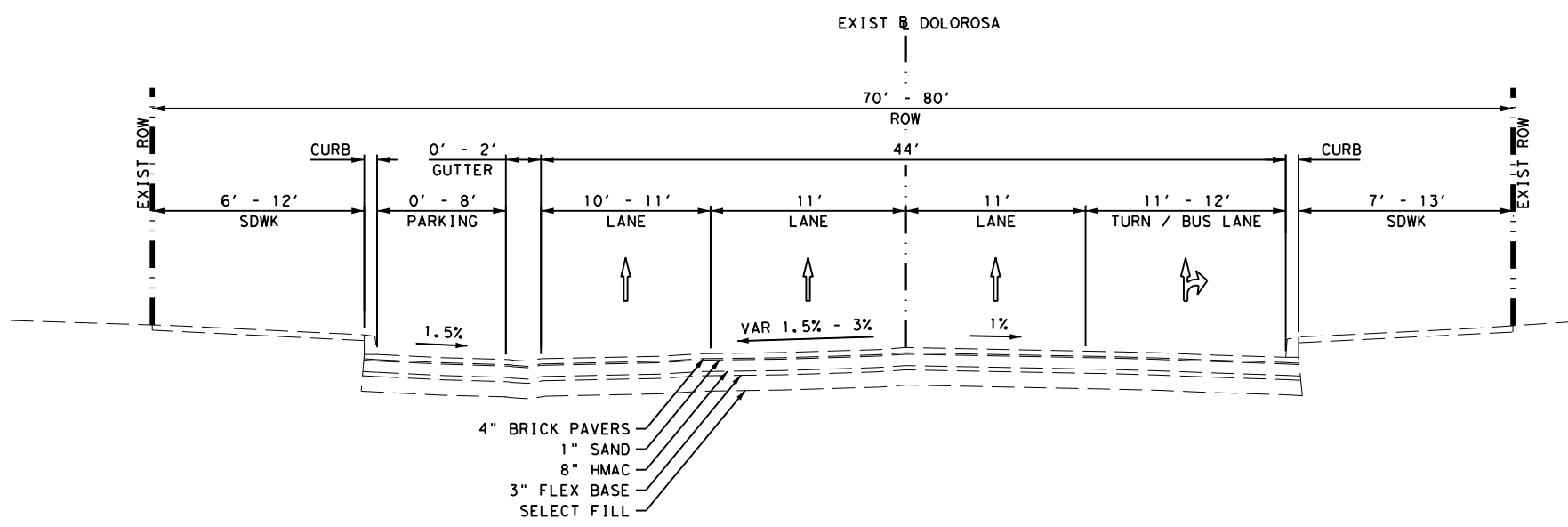

EXISTING TYPICAL SECTION

NTS
STA 49+04 TO END PROJECT

NOTES:

1. LND DESIGNATES LANDSCAPE AREAS.

DESIGN

INTERIM REVIEW
DOCUMENT INCOMPLETE. NOT INTENDED FOR PERMIT, BIDDING OR CONSTRUCTION.
ENGINEER: STEVEN J. TATE
P.E. SERIAL NO: 131443
DATE: 1/24/2023

APPROVAL

INTERIM REVIEW
DOCUMENT INCOMPLETE. NOT INTENDED FOR PERMIT, BIDDING OR CONSTRUCTION.
ENGINEER: JOHN A. TYLER
P.E. SERIAL NO: 105193
DATE: 1/24/2023

NOT TO SCALE

REV. NO.	DATE	DESCRIPTION	BY



SAN ANTONIO | AUSTIN | HOUSTON | FORT WORTH | DALLAS
2000 NW LOOP 410 | SAN ANTONIO, TX 78213 | 210.375.9000
TEXAS ENGINEERING FIRM #470 | TEXAS SURVEYING FIRM #10028800



CITY OF SAN ANTONIO
PUBLIC WORKS DEPARTMENT

DOLOROSA

EXISTING TYPICAL

SHEET 3 OF 3

DESIGN	CHECKED	DRAWN	PROJECT NO.	SUBMITTAL	SHEET NO.
ST	JT	JG	23-03763	70%	15

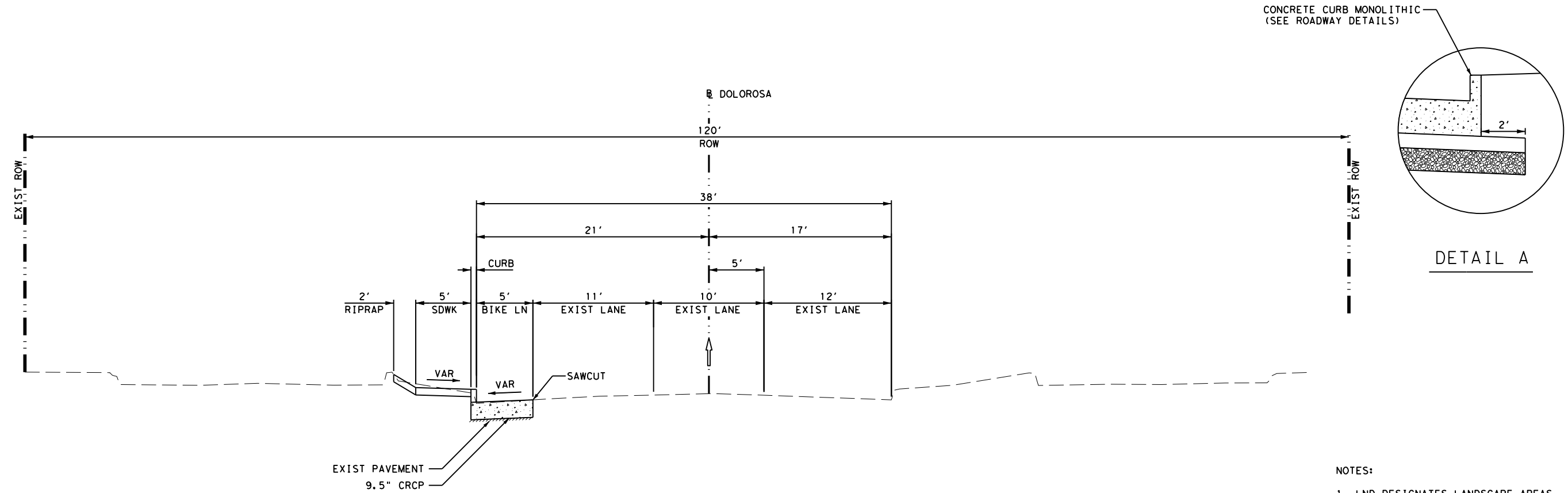

PROPOSED TYPICAL SECTION

NTS
BEGIN PROJECT TO STA 23+79

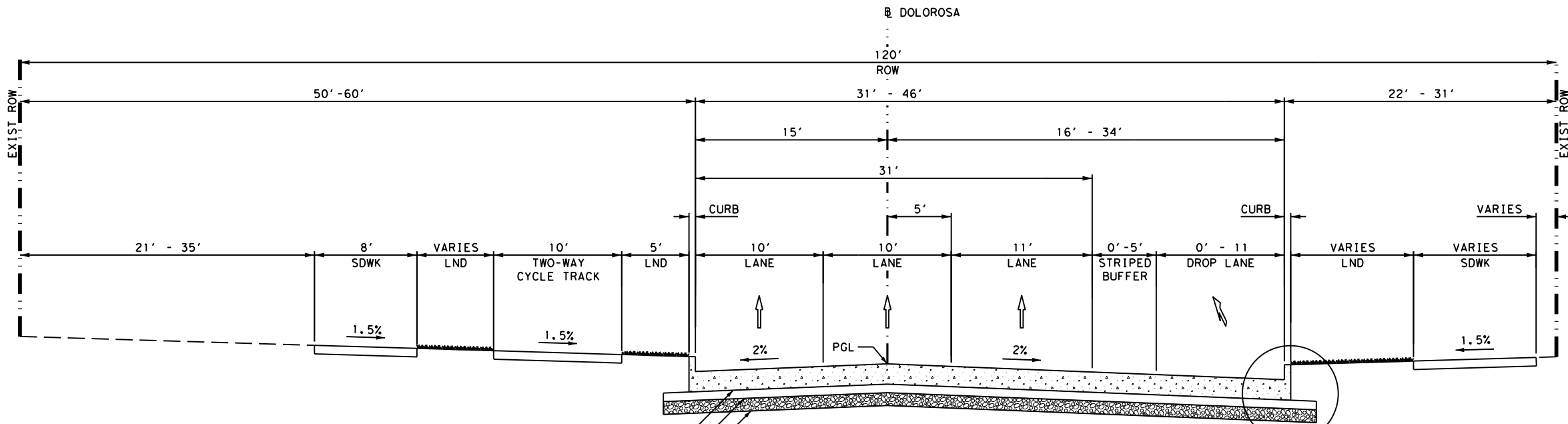

PROPOSED TYPICAL SECTION

NTS
STA 25+22 TO STA 28+56

9.5" CRCP
4" TY B HMA
6" SELECT FILL

SEE DETAIL A

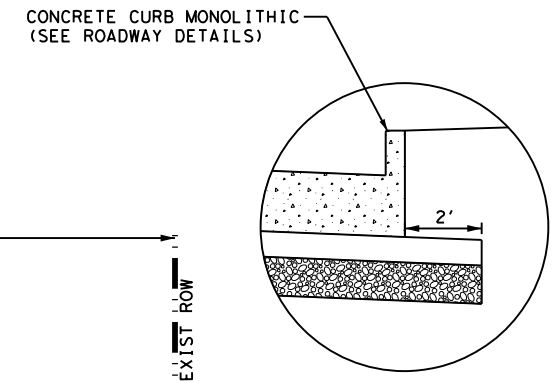

DETAIL A

NOTES:

1. LND DESIGNATES LANDSCAPE AREAS. SEE LANDSCAPE PLANS FOR ADDITIONAL INFORMATION.

DESIGN

INTERIM REVIEW	
DOCUMENT INCOMPLETE. NOT INTENDED FOR PERMIT, BIDDING OR CONSTRUCTION.	
ENGINEER:	STEVEN J. TATE
P.E. SERIAL NO:	131443
DATE:	1/24/2023

APPROVAL

INTERIM REVIEW	
DOCUMENT INCOMPLETE. NOT INTENDED FOR PERMIT, BIDDING OR CONSTRUCTION.	
ENGINEER:	JOHN A. TYLER
P.E. SERIAL NO:	105193
DATE:	1/24/2023

NOT TO SCALE

REV. NO.	DATE	DESCRIPTION	BY



SAN ANTONIO | AUSTIN | HOUSTON | FORT WORTH | DALLAS
2000 NW LOOP 410 | SAN ANTONIO, TX 78213 | 210.375.9000
TEXAS ENGINEERING FIRM #470 | TEXAS SURVEYING FIRM #10028800



CITY OF SAN ANTONIO
PUBLIC WORKS DEPARTMENT

DOLOROSA

PROPOSED TYPICAL

SHEET 1 OF 4

DESIGN	CHECKED	DRAWN	PROJECT NO.	SUBMITTAL	SHEET NO.
ST	JT	JG	23-03763	70%	16

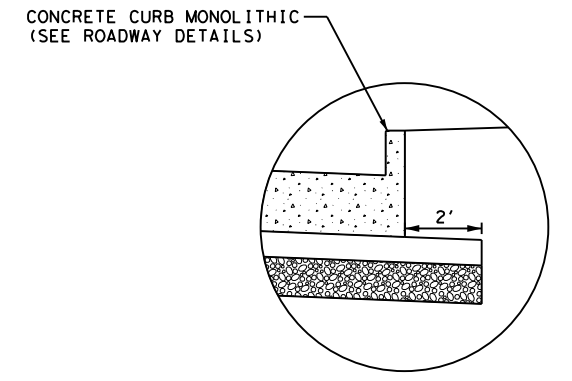
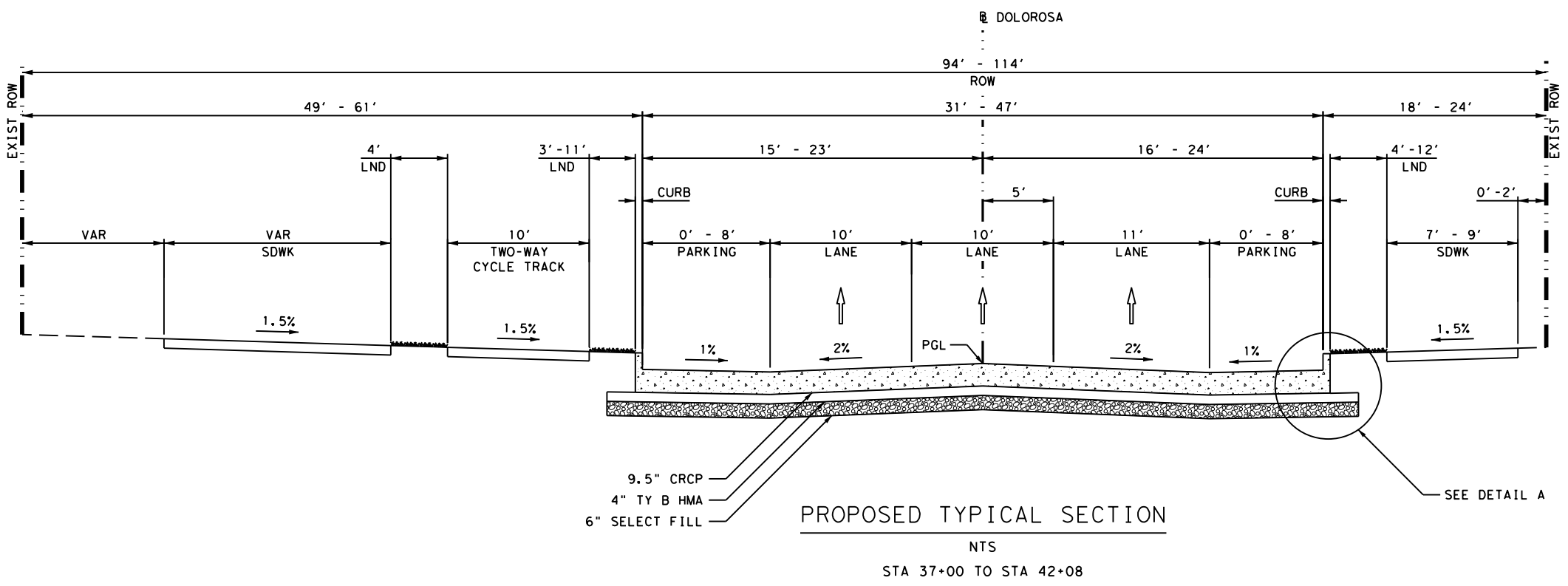
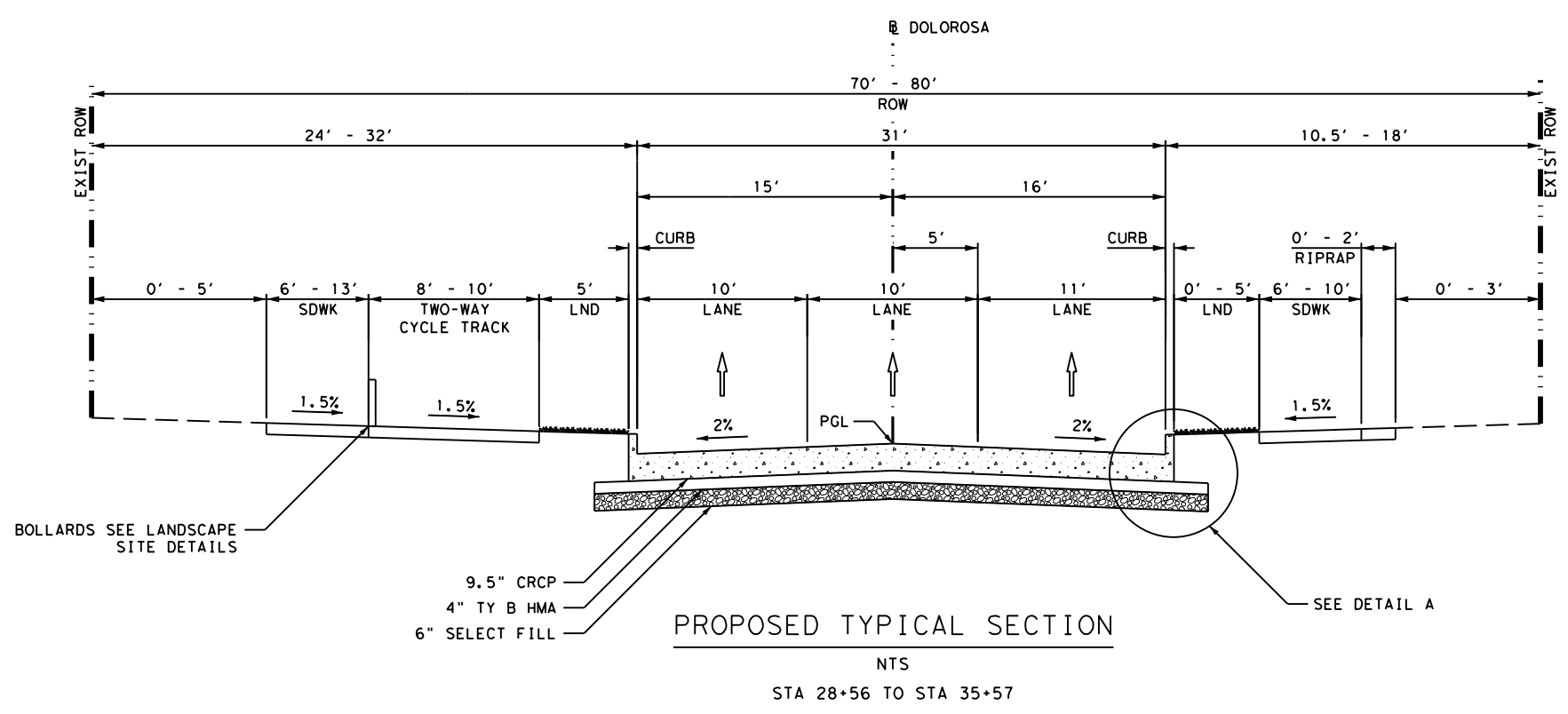

DETAIL A

NOTES:

- 1. LND DESIGNATES LANDSCAPE AREAS. SEE LANDSCAPE PLANS FOR ADDITIONAL INFORMATION.

DESIGN

INTERIM REVIEW
 DOCUMENT INCOMPLETE. NOT INTENDED FOR PERMIT, BIDDING OR CONSTRUCTION.
 ENGINEER: STEVEN J. TATE
 P.E. SERIAL NO: 131443
 DATE: 1/24/2023

APPROVAL

INTERIM REVIEW
 DOCUMENT INCOMPLETE. NOT INTENDED FOR PERMIT, BIDDING OR CONSTRUCTION.
 ENGINEER: JOHN A. TYLER
 P.E. SERIAL NO: 105193
 DATE: 1/24/2023

NOT TO SCALE

REV. NO.	DATE	DESCRIPTION	BY

PAPE-DAWSON ENGINEERS

SAN ANTONIO | AUSTIN | HOUSTON | FORT WORTH | DALLAS
 2000 NW LOOP 410 | SAN ANTONIO, TX 78213 | 210.375.9000
 TEXAS ENGINEERING FIRM #470 | TEXAS SURVEYING FIRM #10028800



CITY OF SAN ANTONIO
PUBLIC WORKS DEPARTMENT

DOLOROSA

PROPOSED TYPICAL

SHEET 2 OF 4

DESIGN	CHECKED	DRAWN	PROJECT NO.	SUBMITTAL	SHEET NO.
ST	JT	JG	23-03763	70%	17

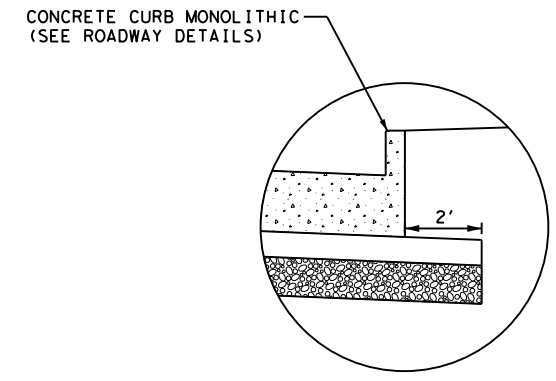
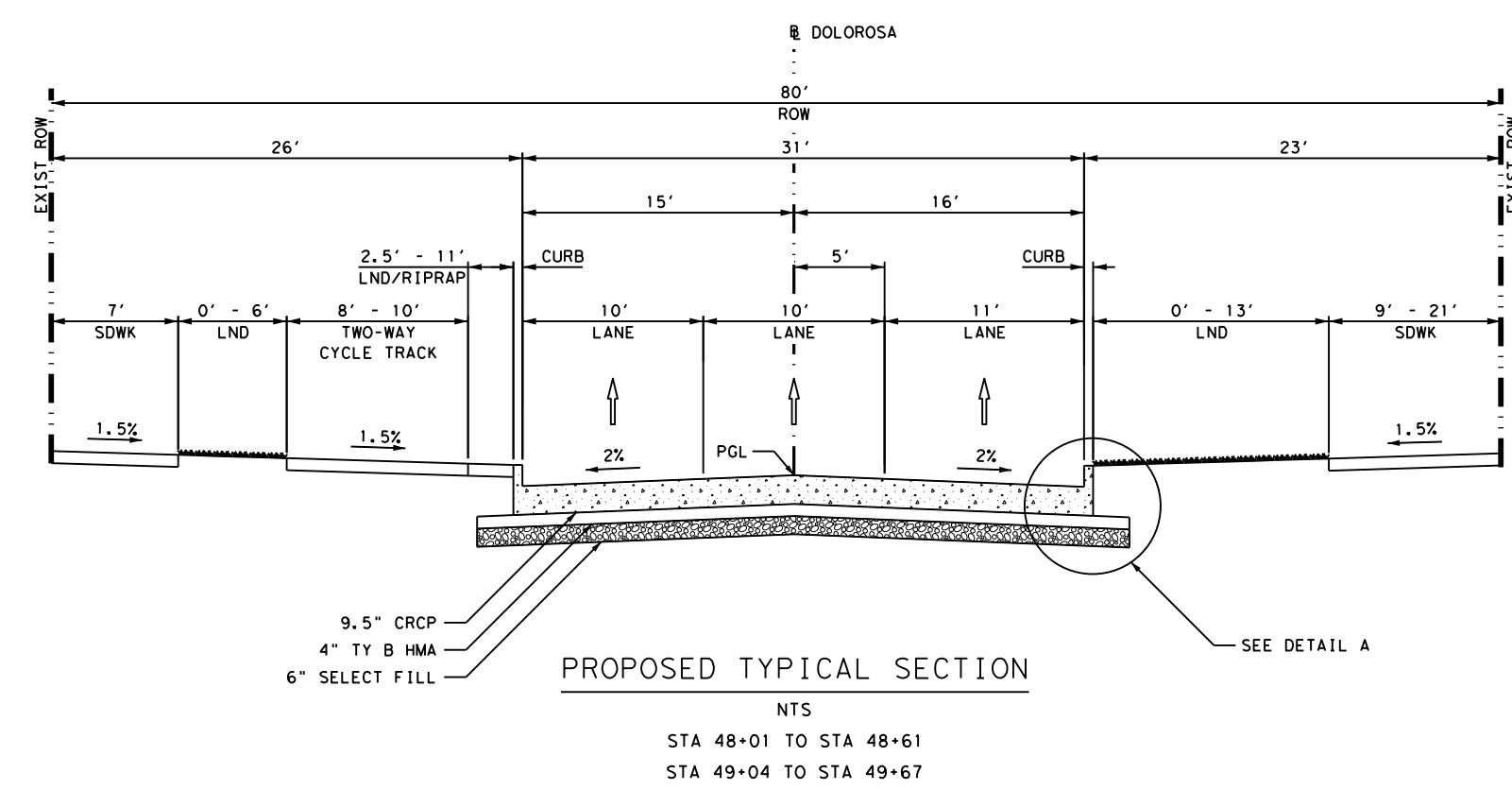
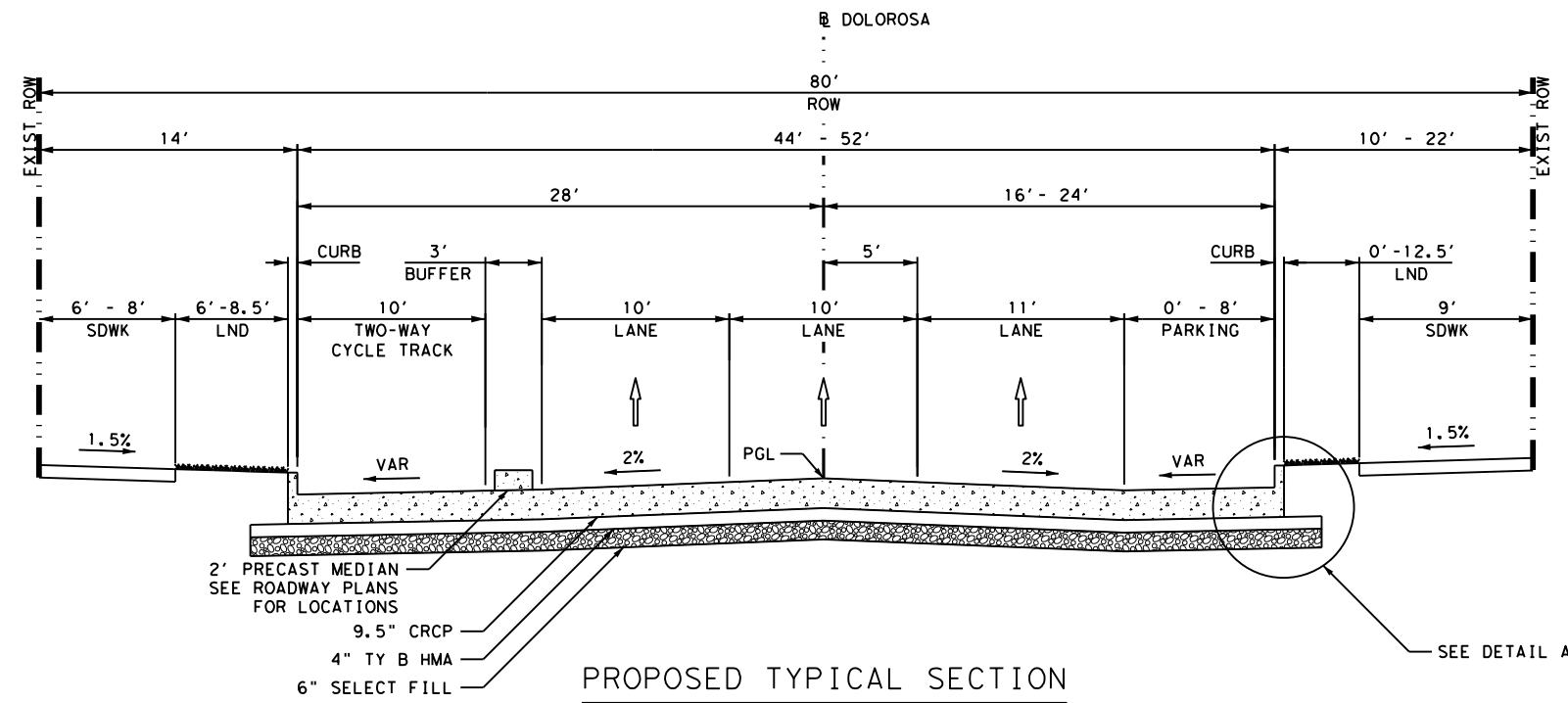

DETAIL A

NOTES:

1. LND DESIGNATES LANDSCAPE AREAS. SEE LANDSCAPE PLANS FOR ADDITIONAL INFORMATION.

DESIGN

INTERIM REVIEW
DOCUMENT INCOMPLETE. NOT INTENDED FOR PERMIT, BIDDING OR CONSTRUCTION.
ENGINEER: STEVEN J. TATE
P.E. SERIAL NO: 131443
DATE: 1/24/2023

APPROVAL

INTERIM REVIEW
DOCUMENT INCOMPLETE. NOT INTENDED FOR PERMIT, BIDDING OR CONSTRUCTION.
ENGINEER: JOHN A. TYLER
P.E. SERIAL NO: 105193
DATE: 1/24/2023

NOT TO SCALE

REV. NO.	DATE	DESCRIPTION	BY



SAN ANTONIO | AUSTIN | HOUSTON | FORT WORTH | DALLAS
2000 NW LOOP 410 | SAN ANTONIO, TX 78213 | 210.375.9000
TEXAS ENGINEERING FIRM #470 | TEXAS SURVEYING FIRM #10028800



CITY OF SAN ANTONIO
PUBLIC WORKS DEPARTMENT

DOLOROSA
PROPOSED TYPICAL

SHEET 3 OF 4

DESIGN	CHECKED	DRAWN	PROJECT NO.	SUBMITTAL	SHEET NO.
ST	JT	JG	23-03763	70%	18

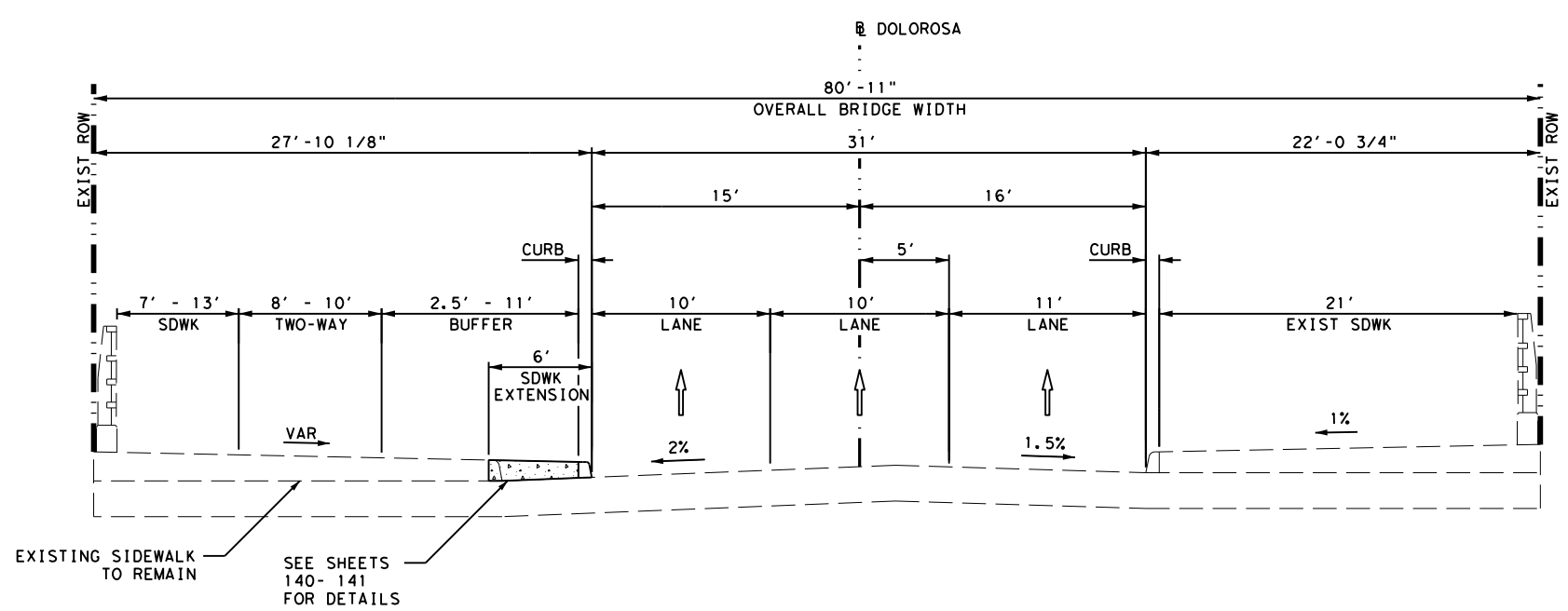

PROPOSED TYPICAL SECTION
NTS
STA 48+61 TO STA 49+04

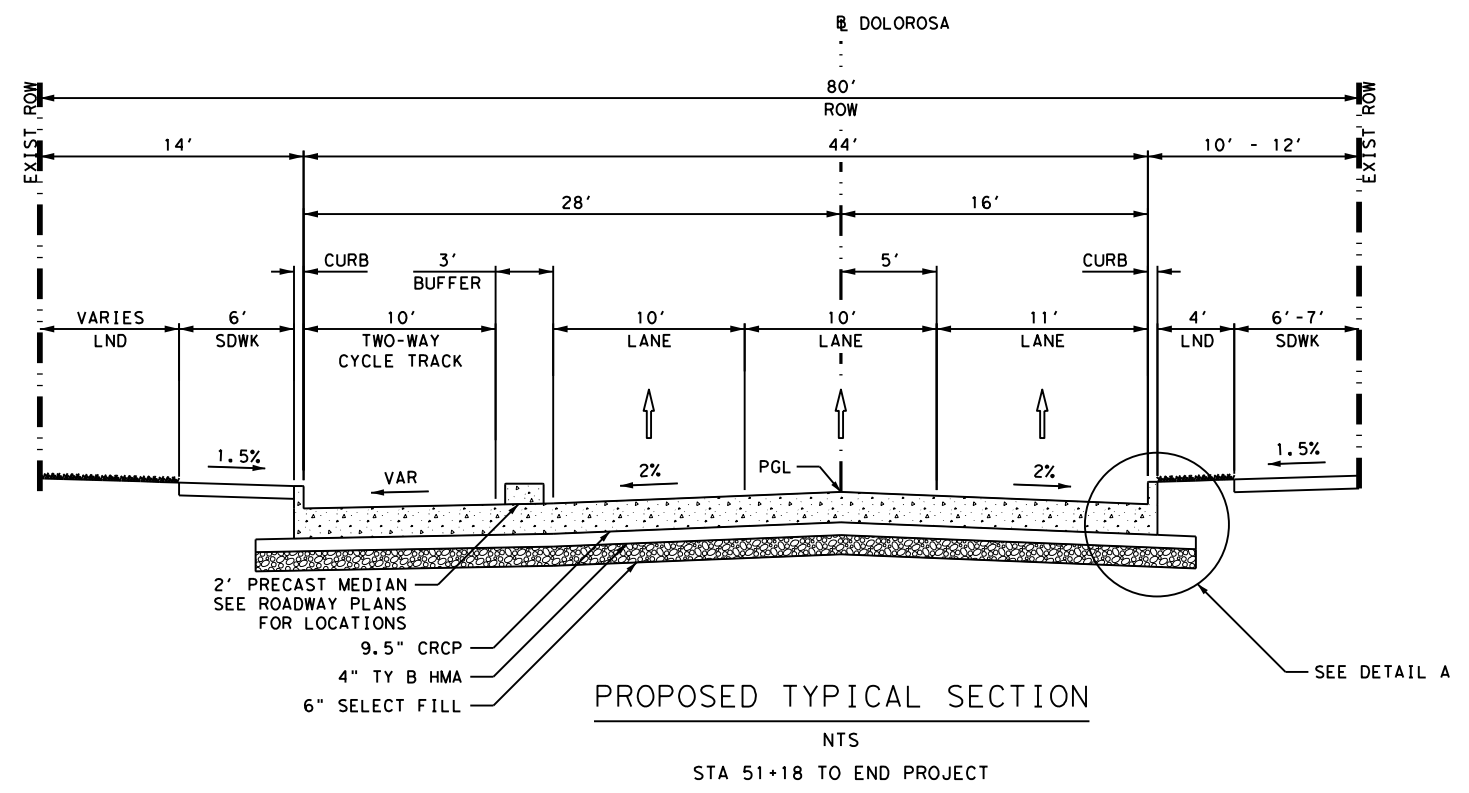

PROPOSED TYPICAL SECTION
NTS
STA 51+18 TO END PROJECT

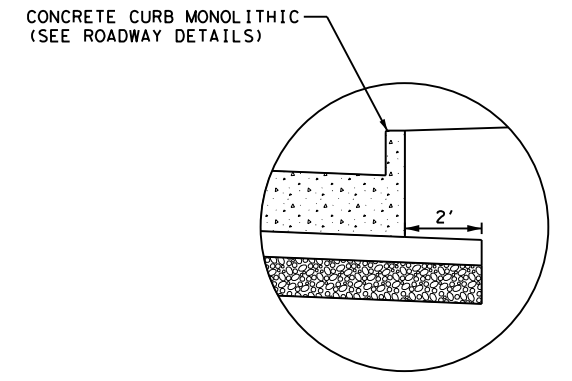

DETAIL A

NOTES:

1. LND DESIGNATES LANDSCAPE AREAS. SEE LANDSCAPE PLANS FOR ADDITIONAL INFORMATION.

DESIGN

INTERIM REVIEW
DOCUMENT INCOMPLETE. NOT INTENDED FOR PERMIT, BIDDING OR CONSTRUCTION.
ENGINEER: STEVEN J. TATE
P.E. SERIAL NO: 131443
DATE: 1/24/2023

APPROVAL

INTERIM REVIEW
DOCUMENT INCOMPLETE. NOT INTENDED FOR PERMIT, BIDDING OR CONSTRUCTION.
ENGINEER: JOHN A. TYLER
P.E. SERIAL NO: 105193
DATE: 1/24/2023

NOT TO SCALE

REV. NO.	DATE	DESCRIPTION	BY



SAN ANTONIO | AUSTIN | HOUSTON | FORT WORTH | DALLAS
2000 NW LOOP 410 | SAN ANTONIO, TX 78213 | 210.375.9000
TEXAS ENGINEERING FIRM #470 | TEXAS SURVEYING FIRM #10028800



CITY OF SAN ANTONIO
PUBLIC WORKS DEPARTMENT

DOLOROSA

PROPOSED TYPICAL

SHEET 4 OF 4

DESIGN	CHECKED	DRAWN	PROJECT NO.	SUBMITTAL	SHEET NO.
ST	JT	JG	23-03763	70%	19

THIS SHEET INTENTIONALLY BLANK

REV. NO.	DATE	DESCRIPTION	BY



SAN ANTONIO | AUSTIN | HOUSTON | FORT WORTH | DALLAS
 2000 NW LOOP 410 | SAN ANTONIO, TX 78213 | 210.375.9000
 TEXAS ENGINEERING FIRM #470 | TEXAS SURVEYING FIRM #10028800



CITY OF SAN ANTONIO
PUBLIC WORKS DEPARTMENT

DOLOROSA
**ESTIMATE & QUANTITY
 SUMMARY**

SHEET 1 OF 1



DESIGN	CHECKED	DRAWN	PROJECT NO.	SUBMITTAL	SHEET NO.
ST	JT	JG	23-03763	70%	20

need spec

ITEM	540.7	5000	0508-6001	0662-6063	0662-6071	0662-6075	0677-6001	0677-6003	0677-6007	0677-6008
TRAFFIC CONTROL PLAN	CONSTRUCTION PERIMETER FENCE	WATER FILLED BARRIER	CONSTRUCTING DETOURS	WK ZN PAV MRK REMOV (W)4" (SLD)	WK ZN PAV MRK REMOV (W)8" (SLD)	WK ZN PAV MRK REMOV (W)24" (SLD)	ELIM EXT PAV MRK & MRKS (4")	ELIM EXT PAV MRK & MRKS (8")	ELIM EXT PAV MRK & MRKS (24")	ELIM EXT PAV MRK & MRKS (ARROW)
	LF	LF	SY	LF	LF	LF	LF	LF	LF	EA
TRAFFIC CONTROL PLAN LAYOUT PHASE 1 STEP 1 (SHEET 1 OF 3)				643			161			
TRAFFIC CONTROL PLAN LAYOUT PHASE 1 STEP 1 (SHEET 2 OF 3)	268	180		763			288			
TRAFFIC CONTROL PLAN LAYOUT PHASE 1 STEP 1 (SHEET 3 OF 3)	533	507		438			67			
TRAFFIC CONTROL PLAN LAYOUT PHASE 1 STEP 2 (SHEET 1 OF 5)										
TRAFFIC CONTROL PLAN LAYOUT PHASE 1 STEP 2 (SHEET 2 OF 5)	176									
TRAFFIC CONTROL PLAN LAYOUT PHASE 1 STEP 2 (SHEET 3 OF 5)	591	57		500	108	12	111	20		
TRAFFIC CONTROL PLAN LAYOUT PHASE 1 STEP 2 (SHEET 4 OF 5)	760	547	53	1209			68	397	84	1
TRAFFIC CONTROL PLAN LAYOUT PHASE 1 STEP 2 (SHEET 5 OF 5)			125							
TRAFFIC CONTROL PLAN LAYOUT PHASE 1 STEP 3 (SHEET 1 OF 6)										
TRAFFIC CONTROL PLAN LAYOUT PHASE 1 STEP 3 (SHEET 2 OF 6)										
TRAFFIC CONTROL PLAN LAYOUT PHASE 1 STEP 3 (SHEET 3 OF 6)										
TRAFFIC CONTROL PLAN LAYOUT PHASE 1 STEP 3 (SHEET 4 OF 6)				472						
TRAFFIC CONTROL PLAN LAYOUT PHASE 1 STEP 3 (SHEET 5 OF 6)	750	655	39	1189			149			
TRAFFIC CONTROL PLAN LAYOUT PHASE 1 STEP 3 (SHEET 6 OF 6)	316	216		286	110		50			
TRAFFIC CONTROL PLAN LAYOUT PHASE 2 (SHEET 1 OF 6)				642			161			
TRAFFIC CONTROL PLAN LAYOUT PHASE 2 (SHEET 2 OF 6)	259			731	211	14	8			
TRAFFIC CONTROL PLAN LAYOUT PHASE 2 (SHEET 3 OF 6)	861	100		779		19				
TRAFFIC CONTROL PLAN LAYOUT PHASE 2 (SHEET 4 OF 6)	1039	66		241		11				
TRAFFIC CONTROL PLAN LAYOUT PHASE 2 (SHEET 5 OF 6)	767	20		180						
TRAFFIC CONTROL PLAN LAYOUT PHASE 2 (SHEET 6 OF 6)	367	20			82	22				
PROJECT TOTAL	6687	2368	217	8073	511	78	1063	417	84	1



* FOR CONTRACTORS INFORMATION ONLY.

Distinguish between COSA items and TXDOT items

REV. NO.	DATE	DESCRIPTION	BY
CAMACHO-HERNANDEZ & ASSOCIATES, LLC 415 EMBASSY OAKS - SUITE 205 SAN ANTONIO, TX. 78216 OFFICE: (210) 341-6200 FAX: (210) 341-6300 FIRM NUMBER: F-8478			
 PAPE-DAWSON ENGINEERS SAN ANTONIO AUSTIN HOUSTON FORT WORTH DALLAS 2000 NW LOOP 410 SAN ANTONIO, TX 78213 210.375.9000 TEXAS ENGINEERING FIRM #470 TEXAS SURVEYING FIRM #10028800			
 CITY OF SAN ANTONIO PUBLIC WORKS DEPARTMENT DOLOROSA TCP QUANTITY SUMMARY			
SHEET 1 OF 1			
DESIGN	CHECKED	DRAWN	PROJECT NO.
MGR	JH	HR	23-03763
SUBMITTAL		SHEET NO.	
70%		21	

ITEM	515.1	516.1	540.6	540.6	540.8	7012-6001
SW3P	TOPSOIL	BERMUDA SODDING	CONSTRUCTION EXITS (INSTALL)	CONSTRUCTION EXITS (REMOVE)	SANDBAGS FOR EROSION CONTROL	CURB INLET SEDIMENT PROTECTION
	CY	SY	SY	SY	LF	LF
SW3P LAYOUTS (SHEET 1 OF 5)	6	58	156	156		90
SW3P LAYOUTS (SHEET 2 OF 5)	25	227	312	312	8	63
SW3P LAYOUTS (SHEET 3 OF 5)			468	468	12	45
SW3P LAYOUTS (SHEET 4 OF 5)			156	156	4	126
SW3P LAYOUTS (SHEET 5 OF 5)			156	156	4	
PROJECT TOTAL	31	285	1248	1248	28	324

Distinguish between
 COSA items and TXDOT
 items

REV. NO.	DATE	DESCRIPTION	BY
CAMACHO-HERNANDEZ & ASSOCIATES, LLC 415 EMBASSY OAKS - SUITE 205 SAN ANTONIO, TX. 78216 OFFICE: (210) 341-6200 FAX: (210) 341-6300 FIRM NUMBER: F-8478			
 PAPE-DAWSON ENGINEERS SAN ANTONIO AUSTIN HOUSTON FORT WORTH DALLAS 2000 NW LOOP 410 SAN ANTONIO, TX 78213 210.375.9000 TEXAS ENGINEERING FIRM #470 TEXAS SURVEYING FIRM #10028800			
 CITY OF SAN ANTONIO PUBLIC WORKS DEPARTMENT DOLOROSA SW3P QUANTITY SUMMARY			
SHEET 1 OF 1			
DESIGN	CHECKED	DRAWN	PROJECT NO.
MGR	JH	HR	23-03763
SUBMITTAL		SHEET NO.	
70%		22	

REMOVAL QUANTITY SUMMARY

SHT NO	ITEM	103.1 Remove Concrete Curb	**0104-6040 REMOVING CONC. (PAVERS)	**0105-6082 REMOVING STAB BASE & ASPH PV (10 TO 16")	**103.4 REMOVE MISCELLANEOUS CONCRETE	*0105-6008 REMOVING STAB BASE AND ASPH PAV (6")	*0496-6007 REMOV STR (PIPE)	*103.3 REMOVE SIDEWALK AND DRIVEWAYS	0496-6002 REMOV STR (INLET)	0496-6003 REMOV STR (MANHOLE)	0542-6001 REMOVE METAL BEAM GUARD FENCE	0542-6002 REMOVE TERMINAL ANCHOR SECTION
	REMOVALS	LF	SF	SY	SF	SY	LF	SF	EA	EA	LF	EA
106	REMOVAL LAYOUTS	513	109	1090	677		96	5790	3	1	50	1
107	REMOVAL LAYOUTS	804		1996			119	24327	2	1		
108	REMOVAL LAYOUTS	880	634	2429	184	109		5451				
109	REMOVAL LAYOUTS	418	106	3482	836			6031	2			
110	REMOVAL LAYOUTS	740	397	3078	1376	18		4805				
111	REMOVAL LAYOUTS	637	1819	42	713			9021				
112	REMOVAL LAYOUTS	711	1321		471	28		7721	2			
113	REMOVAL LAYOUTS	650	1510		155			6234				
	TOTALS	5353	5896	12117	4412	151	243	69380	9	2	50	1

Case

SY? Does this need to be separate items for sidewalk pavers and roadway?

Distinguish between COSA items and TXDOT items

To which item is this subsidiary?

To which item is this subsidiary?

NOTES:
 * FOR CONTRACTORS INFORMATION ONLY, PAYMENT FOR REMOVAL IS SUBSIDIARY TO VARIOUS ITEMS.
 ** REMOVAL OF EXISTING PAVEMENT AND/OR PAVERS IS SUBSIDIARY TO STREET EXCAVATION.

REV. NO.	DATE	DESCRIPTION	BY

Pape-Dawson ENGINEERS
 SAN ANTONIO | AUSTIN | HOUSTON | FORT WORTH | DALLAS
 2000 NW LOOP 410 | SAN ANTONIO, TX 78213 | 210.375.9000
 TEXAS ENGINEERING FIRM #470 | TEXAS SURVEYING FIRM #10028800

CITY OF SAN ANTONIO PUBLIC WORKS DEPARTMENT

DOLOROSA
REMOVAL QUANTITY SUMMARY

DESIGN	CHECKED	DRAWN	PROJECT NO.	SUBMITTAL	SHEET NO.
ST	JT	JG	23-03763	70%	23

P: \\122\27\03\Design\Civil\Summaries\1222703_Rawy_SUMM01.dgn
 Design File name: P:\122\27\03\Design\Civil\Summaries\1222703_Rawy_SUMM01.dgn
 Plotted on: 1/25/2023 2:23:19 PM

ROADWAY QUANTITY SUMMARY

ITEM		104.1	107.1	107.4	205.2	209.1	209.2	500.1
ROADWAY		STREET EXCAVATION	EMBANKMENT (FINAL)	EMBANKMENT (FINAL) (TYPE A)	HMA PAVEMENT, TYPE B (4" COMP. DEPTH)	CONCRETE PAVEMENT (9.5" CRCP)	CONCRETE PAVEMENT (9.5" HES)	CONCRETE CURB
SHT NO		CY	CY	CY	SY	SY	SY	LF
114	ROADWAY PLAN & PROFILE	689.0	31.0	161.0	963	908		166
115	ROADWAY PLAN & PROFILE	1268.0	36.0	315.0	1887	1689		121
116	ROADWAY PLAN & PROFILE	1455.0	64.0	328.0	1966	1075	686	228
117	ROADWAY PLAN & PROFILE	802.0	71.0	189.0	1130	989		63
118	ROADWAY PLAN & PROFILE	1186.0	302.0	252.0	1507	1343		340
119	ROADWAY PLAN & PROFILE	1325.0	64.0	340.0	2038	1877		242
120	ROADWAY PLAN & PROFILE	1169.0	57.0	304.0	1824	1668		100
121	ROADWAY PLAN & PROFILE	961.0	28.0	280.0	1676	1403	134	24
TOTALS		8855.0	653.0	2169.0	12991	10952	820	1284

ITEM		500.2	500.5	500.6	502.1	502.3	503.1	503.2
ROADWAY		CONCRETE CURB (MONO)	CONCRETE CURB (MOUNTABLE)	RIBBON CURB	CONC SIDEWALKS CONV FORMED	CONC SIDEWALKS (EXTENSION)	PORTLAND CEMENT CONCRETE DRIVEWAY	PCC DRIVEWAY COMMERCIAL
SHT NO		LF	LF	LF	SY	SY	SY	SY
114	ROADWAY PLAN & PROFILE	325			728		67	
115	ROADWAY PLAN & PROFILE	697			1048		50	
116	ROADWAY PLAN & PROFILE	525	43	47	1081		184	30
117	ROADWAY PLAN & PROFILE	275	237	49	773		416	230
118	ROADWAY PLAN & PROFILE	248	58	32	983		172	44
119	ROADWAY PLAN & PROFILE	446			577		74	
120	ROADWAY PLAN & PROFILE	541			804	28		
121	ROADWAY PLAN & PROFILE	504			413		104	
TOTALS		3561	338	128	6407	28	1067	304

include spec

ITEM		505.1	506.1	618.3	824	833	0247-6044	0420-6002
ROADWAY		CONCRETE RIPRAP (4 INCHES THICK)	CONCRETE RETAINING WALLS COMBINATION TYPE	CONDUIT (4 INCH/PVC SCH 40)	1" SMALL WATER SERVICE	1" IRRIGATION METER AND METER BOX (COMPLETE)	FL BS (CMP IN PLC) (TY A GR 4) (FNAL POS)	CL A CONC (MISC)
SHT NO		SY	CY	LF	EA	EA	CY	CY
114	ROADWAY PLAN & PROFILE	57	2.0					
115	ROADWAY PLAN & PROFILE	27			1	1		
116	ROADWAY PLAN & PROFILE	90					43.0	
117	ROADWAY PLAN & PROFILE	19	1.0					0.5
118	ROADWAY PLAN & PROFILE	1		180	1			
119	ROADWAY PLAN & PROFILE	5	69.0	22				6.5
120	ROADWAY PLAN & PROFILE	22			2	2		7.0
121	ROADWAY PLAN & PROFILE	12		50				6.0
TOTALS		233	72.0	252	4	3	43.0	20.0

ITEM		0420-6074	0454-6001	0528-6006	0529-6020	0531-6018	0531-6019	0531-6022
ROADWAY		CL C CONC (MISC)	SEALED EXPANSION JOINT (4 IN) (SEJ - A)	REMOVE AND RELAY PAVERS	CONC CURB & GUTTER (ARMOR CURB)	CURB RAMPS (TY 1)	CURB RAMPS (TY 2)	CURB RAMPS (TY 5)
SHT NO		CY	LF	SY	LF	SY	SY	SY
114	ROADWAY PLAN & PROFILE					65		
115	ROADWAY PLAN & PROFILE	6.0				78	20	
116	ROADWAY PLAN & PROFILE		41		14	187		
117	ROADWAY PLAN & PROFILE	6.0	34	9				
118	ROADWAY PLAN & PROFILE		46	181		44		
119	ROADWAY PLAN & PROFILE	6.0				72		
120	ROADWAY PLAN & PROFILE					28		
121	ROADWAY PLAN & PROFILE	1.0				17		100
TOTALS		19.0	121	190	14	491	20	100

Distinguish between COSA items and TXDOT items

REV. NO.	DATE	DESCRIPTION	BY
<p style="margin: 0;">SAN ANTONIO AUSTIN HOUSTON FORT WORTH DALLAS 2000 NW LOOP 410 SAN ANTONIO, TX 78213 210.375.9000 TEXAS ENGINEERING FIRM #470 TEXAS SURVEYING FIRM #10028800</p>			
<p style="margin: 0;">CITY OF SAN ANTONIO PUBLIC WORKS DEPARTMENT</p>			
<p style="margin: 0;">DOLOROSA ROADWAY QUANTITY SUMMARY</p>			
SHEET 1 OF 2			
DESIGN	CHECKED	DRAWN	PROJECT NO.
ST	JT	JG	23-03763
SUBMITTAL		SHEET NO.	
70%		24	

ITEM		0531-6023	0531-6027	0540-6013	0540-6016	3076-6031	3076-6066	5008-6001
ROADWAY		CURB RAMP (TY 6)	CURB RAMP (TY 10)	TRANSITION ADJUSTMENT	DOWNSTREAM ANCHOR TERMINAL SECTION	D-GR HMA TY-C PG76-22	TACK COAT	WHEEL STOPS
SHT NO		SY	SY	EA	EA	TON	GAL	EA
114	ROADWAY PLAN & PROFILE			1	1			
115	ROADWAY PLAN & PROFILE							
116	ROADWAY PLAN & PROFILE					50.0	114.00	3
117	ROADWAY PLAN & PROFILE							
118	ROADWAY PLAN & PROFILE							
119	ROADWAY PLAN & PROFILE							
120	ROADWAY PLAN & PROFILE							
121	ROADWAY PLAN & PROFILE	12	14					
TOTALS		12	14	1	1	50.0	114.00	3

ITEM		5113-6001
ROADWAY		WROUGHT IRON FENCE
SHT NO		LF
114	ROADWAY PLAN & PROFILE	
115	ROADWAY PLAN & PROFILE	
116	ROADWAY PLAN & PROFILE	106
117	ROADWAY PLAN & PROFILE	
118	ROADWAY PLAN & PROFILE	
119	ROADWAY PLAN & PROFILE	
120	ROADWAY PLAN & PROFILE	
121	ROADWAY PLAN & PROFILE	
TOTALS		106

Distinguish between COSA items and TXDOT items

REV. NO.	DATE	DESCRIPTION	BY



PAPE-DAWSON ENGINEERS

SAN ANTONIO | AUSTIN | HOUSTON | FORT WORTH | DALLAS
2000 NW LOOP 410 | SAN ANTONIO, TX 78213 | 210.375.9000
TEXAS ENGINEERING FIRM #470 | TEXAS SURVEYING FIRM #10028800



CITY OF SAN ANTONIO
PUBLIC WORKS DEPARTMENT

DOLOROSA
ROADWAY QUANTITY SUMMARY

SHEET 2 OF 2

DESIGN	CHECKED	DRAWN	PROJECT NO.	SUBMITTAL	SHEET NO.
ST	JT	JG	23-03763	70%	25

DRAINAGE QUANTITY SUMMARY

include spec

ITEM	401.112	401.113	403.1	403.14	403.8	403.9	407.4	550.1	858
DRAINAGE SUMMARY	REINFORCED CONCRETE PIPE (CLASS III) (24" DIA)	REINFORCED CONCRETE PIPE (CLASS III) (30" DIA)	JUNCTION BOX (COMPLETE) 4' X 4' X 4'	INLET EXTENSION (10FT)	INLET TY I (COMPLETE) (10 FT)	INLET TY I (COMPLETE) (15 FT)	CONCRETE COLLARS	TRENCH EXCAVATION SAFETY PROTECTION	CONCRETE ENCASEMENT
SHT NO	LF	LF	EA	EA	EA	EA	CY	LF	CY
283	53	49	1		1	2	4	92	
284	95		2	1	2		2	95	
285	414		1			2		414	
286	39	53	1		2		2	92	
288	11	359	2	2	2			359	2
289	143	135	2	1	1	3	2	278	
TOTALS	755	596	9	4	8	7	10	1330	2

ITEM	0465-6031	0465-6158	0481-6014
DRAINAGE SUMMARY	INLET (COMPL) (PCU) (3FT) (RIGHT)	INLET (COMPL) (PAZD) (FG) (3FTX3FT -3FTX3FT)	PIPE (PVC) (SCH 40) (8 IN)
SHT NO	EA	EA	LF
283			
284			
285		1	
286			
288	2		90
289			72
TOTALS	2	1	162

Distinguish between COSA items and TXDOT items

REV. NO.	DATE	DESCRIPTION	BY

PAPE-DAWSON ENGINEERS
 SAN ANTONIO | AUSTIN | HOUSTON | FORT WORTH | DALLAS
 2000 NW LOOP 410 | SAN ANTONIO, TX 78213 | 210.375.9000
 TEXAS ENGINEERING FIRM #470 | TEXAS SURVEYING FIRM #10028800

CITY OF SAN ANTONIO PUBLIC WORKS DEPARTMENT

DOLOROSA DRAINAGE QUANTITY SUMMARY

SHEET 1 OF 1

DESIGN	CHECKED	DRAWN	PROJECT NO.	SUBMITTAL	SHEET NO.
ST	JT	JG	23-03763	70%	26

LANDSCAPE QUANTITY SUMMARY

NOTES:

- ITEM 804.1 IS FOR TREE AND SHRUB MAINTENANCE ONLY AND SHALL BE LUMP SUM.
- REFER TO SEPARATE PAY ITEM FOR TREE AND SHRUB INSTALLATION.

ITEM	DESCRIPTION	UNIT	QUANTITY
GENERAL HARDSCAPE			
03 3500.01	CHEMICAL SURFACE RETARDER FINISH	S.Y.	5,713
03 3500.02	INTEGRAL COLOR CONCRETE ACCENT PLAZA (MID-BLOCK) WITH CHEMICAL SURFACE RETARDER FINISH	S.F.	1,372
03 3500.03	INTEGRAL COLOR CONCRETE GRECA DETAIL(WALKWAYS) WITH CHEMICAL SURFACE RETARDER FINISH (22 S.F. EA.)	S.F.	352
32 1416.02	UNIT PAVER TYPE 2 (MARKET SQUARE)	S.F.	1,860
32 1440.01	PORPHYRY PAVING (WALKWAYS)	S.F.	4,607
32 1440.02	PORPHYRY PAVING GRECA DETAIL (MID-BLOCK)	S.F.	217
32 1440.03	PORPHYRY PAVING (CROSSWALK & ROADWAY)	S.F.	3,839
32 1440.04	PAVER METAL EDGE RESTRAINT	L.F.	113
32 1540.01	CRUSHED STONE MULCH (PLANTING AREAS)	C.Y.	60
SITE AMENITIES			
32 3300.01	CHAIR (BACKED)	EA.	9
32 3300.02	CHAIR (BACKLESS)	EA.	9
32 3300.05	BOLLARD TYPE 1	EA.	89
32 3300.06	BOLLARD TYPE 2 (REMOVABLE)	EA.	3
32 3300.07	BIKE RACK	EA.	28
32 3300.08	TRASH AND RECYCLE BIN (50% TRASH, 50% RECYCLE)	EA.	11
32 3300.09	MOVABLE PLANTER	EA.	75
04 4130.01	BENCH - LIMESTONE BLOCK	EA.	46
05 7000.01	BUS SHELTER INSERT/RELOCATION (SHELTERS PROVIDED BY VIA)	EA.	2
TREES			
32 9300.01	TREE (65 GALLON, 2" CALIPER)	EA.	45
32 9300.02	TREE (100 GALLON, 4" CALIPER)	EA.	92
SHRUBS & PERENNIALS			
32 9300.04	SHRUB / PERENNIAL - 1 GALLON	EA.	377
32 9300.05	SHRUB / PERENNIAL - 2 GALLON	EA.	574
32 9300.06	SHRUB / PERENNIAL - 3 GALLON	EA.	118
32 9300.07	SHRUB / PERENNIAL - 5 GALLON	EA.	367
MISCELLANEOUS			
32 9113.01	STRUCTURAL SOIL	C.Y.	1,917
32 9300.08	PLANTING SOIL (ALL PLANTING AREAS EX. THOSE WITH TREE PRES.)	C.Y.	654
32 9300.09	ARBOR CHIP MULCH	C.Y.	105
32 9300.10	SHEET MULCH	S.Y.	1,249
32 9300.12	STEEL EDGER	L.F.	371
32 9300.13	PRUNING OF EXISTING TREES (ONLY TREES LOCATED WITHIN PUBLIC ROW)	EA.	40
32 9300.14	TREE REMOVAL	EA.	20
801.1	TREE PROTECTION	EA.	94
804.1	NEW TREE AND SHRUB PLANTING AND MAINTENANCE	L.S.	1

include specs

REV. NO.	DATE	DESCRIPTION	BY

MOORE IACOFANO GOLTSMAN, INC.
 317 LEXINGTON AVENUE, SUITE 2
 SAN ANTONIO, TEXAS, CA 78215
 TEL 210-600-9990
 www.migcom.com

PAPE-DAWSON ENGINEERS
 SAN ANTONIO | AUSTIN | HOUSTON | FORT WORTH | DALLAS
 3600 HWY 190P-410 | SAN ANTONIO, TX 78216 | 210.378.9999
 TEXAS ENGINEERING FIRM #479 | TEXAS SURVEYING FIRM #10028990

CITY OF SAN ANTONIO
PUBLIC WORKS DEPARTMENT
 DOLOROSA

LANDSCAPE QUANTITY SUMMARY

DESIGN	CHECKED	DRAWN	PROJECT NO.	SUBMITTAL	SHEET NO.
RD/AM	RD/AM	TM/RD	23-03763	70%	27

GENERAL NOTES:

- A. APPLICABLE TO SUMMARY: THE CONTRACTOR IS RESPONSIBLE TO CONFIRM ALL QUANTITIES PRIOR TO ORDERING MATERIAL OR PLANNING THE INSTALLATION, THE LIST OF MATERIAL QUANTITIES PER THE TX DOT BID ITEMS LIST IS INTENDED TO PROVIDE A GENERAL BASIS FOR A PROBABLE OPINION OF COSTS.

need spec

CoSA Dolorosa Improvements - Illumination Summary Bid Item List

SHEET NUMBER	STATION TO STATION	16050.01	308.1	618.1	618.10	620.1	620.3	624.8	SALVAGE PEDESTRIAN POLE LIGHTS (REMOVE AND RETURN TO OWNER)
		SELUX PEDESTRIAN LIGHT W/ GFI RECEPTACLE (TYPE A)	DRILLED SHAFTS (30")	CONDUIT (2 INCH/PVC SCHEDULE 40)	CONDUIT (1 INCH/PVC SCHEDULE 40)	ELECTRICAL CONDUCTORS (NO. 6) (BARE)	ELECTRICAL CONDUCTORS (NO. 6) (INSULATED)	GROUND BOXES TYPE D (162922) W/APRON	
ILLUMINATION LAYOUTS		EA	LF	LF	LF	LF	LF	EA	EA
SHEET 1 OF 8	BEGIN TO 28+21.00	11	88	219	537	852	3776	4	
SHEET 2 OF 8	28+21. TO 31+60.00	11	88	389	468	875	6984	2	
SHEET 3 OF 8	31+60.00 TO 35+73.00	15	120	75	716	893	3950	2	
SHEET 4 OF 8	35+73.00 TO 41+44.00	15	120	393	1115	1509	10900	4	
SHEET 5 OF 8	41+44.00 TO 46+04.00	13	104	364	509	975	6644	3	
SHEET 6 OF 8	46+04.00 TO 47+81.00	7	56	0	656	698	2458		
SHEET 7 OF 8	47+81.00 TO 51+71.00	8	64	330	437	839	4278	2	
SHEET 8 OF 8	51+71.00 TO END	7	56	59	319	368	1472	2	
Demolition Sheets	BEGIN TO END								44
SHEET BY SHEET TOTALS		87	696	1829	4757	7009	40462	19	44

Review/Revise based on comments.

INTERIM REVIEW
 DOCUMENT INCOMPLETE. NOT INTENDED FOR PERMIT, BIDDING OR CONSTRUCTION.
 ENGINEER: TRAVIS E. WILTSHIRE
 P.E. SERIAL NO: 85219
 COMPANY NAME: CNG ENGINEERING, PLLC.
 COMPANY REG. NO. F-7964
 DATE: 01-20-2023

REV. NO. DATE DESCRIPTION BY



CNG ENGINEERING
 MEP DESIGN | PLANNING | COMMISSIONING
 1917 N NEW BRAUNFELS AVE, SUITE 201
 SAN ANTONIO, TEXAS 78208
 T 210.224.8841 F 210.224.8224
 www.cngengineering.com
 TBPE FIRM # F-7964



PAPE-DAWSON ENGINEERS
 SAN ANTONIO | AUSTIN | HOUSTON | FORT WORTH | DALLAS
 2000 NW LOOP 410 | SAN ANTONIO, TX 78218 | 210.375.9000
 TEXAS ENGINEERING FIRM #170 | TEXAS SURVEYING FIRM #10028800



CITY OF SAN ANTONIO
PUBLIC WORKS DEPARTMENT

DOLOROSA
 ELECTRICAL QUANTITY SUMMARY

DESIGN	CHECKED	DRAWN	PROJECT NO.	SUBMITTAL	SHEET NO.
JC	JC	CDC	23-03763	70%	29

Design File name: P:\122\27\03\Design\Civil\Summaries\1222703_Traffic_SUMM01.dgn
 Plotted on: 1/25/2023 3:34:51 PM

TRAFFIC SIGNAL QUANTITY SUMMARY

include spec

ITEM		615.1	628.2	681.1	682.2	686.31	686.32	686.41	689.2
INTERSECTION		TRAFFIC SIGNAL CONTROLLER ASSEMBLY (TYPE 332)	ELECTRICAL SERVICE (DNTWN NETWORK) (120 / 208V)	TEMPORARY TRAFFIC SIGNALS	INSTALL VEHICLE SIGNAL HEAD WITH BACK PLATE (4 SEC)	INSTALL TRAF. SIGNAL POLE ASSEM. (SINGLE 28' MA)	INSTALL TRAF. SIGNAL POLE ASSEM. (SINGLE 28' MA)	INSTALL TRAF. SIGNAL POLE ASSEM. (DOUBLE 40' -28' MA)	INSTALL POST MOUNTED RECTANGULAR RAPID
SHT NO		EA	EA	EA	EA	EA	EA	EA	EA
415	CONDUIT & CONDUCTOR SCHEDULE BUENA VISTA				2				
423	POLE SCHEDULE & ILSN DETAILS PECOS-TRINIDAD	1		1					
427	CONDUIT & CONDUCTOR SCHEDULE SAN SABA					1			2
434	CONDUIT & CONDUCTOR SCHEDULE DOLOROSA / S SANTA ROSA								
441	CONDUIT & CONDUCTOR SCHEDULE PLAZA DE ARMAS	1	1	1			1	1	2
TOTALS		2	1	2	2	1	1	1	4

include spec

ITEM		691.3	692.1	693.6	693.8	694.1	694.6	8100.1	8100.2
INTERSECTION		COAXIAL CABLE	CCTV COMMUNICATION CABLE	INSTALL INTERNALLY LIGHTED STREET NAME SIGN (DOUBLE SIDED) (LED) (6 FT)	INSTALL INTERNALLY LIGHTED STREET NAME SIGN (DOUBLE SIDED) (LED) (8 FT)	VIVDS PROCESSOR UNIT	VIVDS COMMUNICATION CABLE (COAXIAL)	INSTALL ITS TRAFFIC MONITORING CAMERA ASSEMBLY	INSTALL ITS TRAFFIC MONITORING CAMERA CABLING
SHT NO		LF	LF	EA	EA	EA	LF	EA	EA
415	CONDUIT & CONDUCTOR SCHEDULE BUENA VISTA								
423	POLE SCHEDULE & ILSN DETAILS PECOS-TRINIDAD	265	245			1	360	1	245
427	CONDUIT & CONDUCTOR SCHEDULE SAN SABA								
434	CONDUIT & CONDUCTOR SCHEDULE DOLOROSA / S SANTA ROSA								
441	CONDUIT & CONDUCTOR SCHEDULE PLAZA DE ARMAS		250	1	1			1	250
TOTALS		265	495	1	1	1	360	2	495

ITEM		308.30	308.36	6007.1	618.1	618.2	618.5	620.1	620.2
INTERSECTION		DRILL SHAFTS (30 IN)	DRILL SHAFTS (36 IN)	REMOVE SIGNALIZED INTERSECTION	CONDUIT (PVC SCHEDULE 40) (2 IN)	CONDUIT (PVC SCHEDULE 40) (3 IN)	CONDUIT (PVC SCHEDULE 40) (3 IN) (BORE)	ELECTRICAL CONDUCTORS (NO. 6) (BARE)	ELECTRICAL CONDUCTORS (NO. 8) (BARE)
SHT NO		LF	LF	EA	LF	LF	LF	LF	LF
415	CONDUIT & CONDUCTOR SCHEDULE BUENA VISTA			1	15	45	470		620
423	POLE SCHEDULE & ILSN DETAILS PECOS-TRINIDAD			1	175	880	430	30	1605
427	CONDUIT & CONDUCTOR SCHEDULE SAN SABA	11		1	55	795	375		1320
434	CONDUIT & CONDUCTOR SCHEDULE DOLOROSA / S SANTA ROSA			1		70	285		395
441	CONDUIT & CONDUCTOR SCHEDULE PLAZA DE ARMAS	11	13	1	65	1010	450	15	1395
TOTALS		23	13	5	310	2800	2010	45	5335

ITEM		620.3	624.8	628.1	633.1	655.1	680.1	680.3	682.1
INTERSECTION		ELECTRICAL CONDUCTORS (NO. 6) (INSULATED)	INSTALL GROUND BOXES TYPE D (162922) W/ APRON	ELECTRICAL SERVICE (TYPE D) (120 / 240V)	BATTERY BACKUP SYSTEM (EXTERNAL CABINET)	TYPE 332 CONTROLLER FOUNDATION	INSTALLATION OF HIGHWAY TRAFFIC SIGNALS (ISOLATED)	INSTALLATION OF HIGHWAY TRAFFIC SIGNALS (PARTIAL INTERSECTION)	INSTALL VEHICLE SIGNAL HEAD WITH BACK PLATE (3 SEC)
SHT NO		LF	EA	EA	EA	EA	EA	EA	EA
415	CONDUIT & CONDUCTOR SCHEDULE BUENA VISTA							1	9
423	POLE SCHEDULE & ILSN DETAILS PECOS-TRINIDAD	55	4	1	1	1	1		13
427	CONDUIT & CONDUCTOR SCHEDULE SAN SABA							1	5
434	CONDUIT & CONDUCTOR SCHEDULE DOLOROSA / S SANTA ROSA							1	2
441	CONDUIT & CONDUCTOR SCHEDULE PLAZA DE ARMAS	25	4		1	1	1		
TOTALS		80	8	1	2	2	2	3	29

REV. NO.	DATE	DESCRIPTION					BY			
 PAPE-DAWSON ENGINEERS <small>SAN ANTONIO AUSTIN HOUSTON FORT WORTH DALLAS 2000 NW LOOP 410 SAN ANTONIO, TX 78213 210.375.9000 TEXAS ENGINEERING FIRM #470 TEXAS SURVEYING FIRM #10028800</small>										
 CITY OF SAN ANTONIO PUBLIC WORKS DEPARTMENT										
DOLOROSA TRAFFIC SIGNAL QUANTITY SUMMARY										
SHEET 1 OF 2										
DESIGN	CHECKED	DRAWN	PROJECT NO.	SUBMITTAL	SHEET NO.					
ST	JT	JG	23-03763	70%	30					

TRAFFIC SIGNAL QUANTITY SUMMARY

include spec

ITEM		682.3	682.4	684.1 (4)	684.1 (9)	684.1 (3)	687.1	688.3	699.1
INTERSECTION		INSTALL VEHICLE SIGNAL HEAD WITH BACK PLATE (5 SEC)	INSTALL PEDESTRIAN SIGNAL HEAD (12 IN) LED (2 IND)	TRAFFIC SIGNAL CABLES (TYPE A) (14 AWG) (4 CONDUCTOR)	TRAFFIC SIGNAL CABLES (TYPE A) (14 AWG) (9 CONDUCTOR)	TRAFFIC SIGNAL CABLES (TYPE A) (16 AWG) (3 CONDUCTOR) (STRANDED)	INSTALL PEDESTAL POLE ASSEMBLY	INSTALL AUDIBLE PED. DETECT. (2 IN TACTILE PUSH BTN AND SIGN)	INSTALL FEDS PROCESSOR UNIT
SHT NO		EA	EA	LF	LF	LF	EA	EA	EA
415	CONDUIT & CONDUCTOR SCHEDULE BUENA VISTA	1	1		595	250	2	1	1
423	POLE SCHEDULE & ILSN DETAILS PECOS-TRINIDAD		8		2355	1565	10	9	1
427	CONDUIT & CONDUCTOR SCHEDULE SAN SABA		2		1300	790	2		
434	CONDUIT & CONDUCTOR SCHEDULE DOLOROSA / S SANTA ROSA		2		450		2		
441	CONDUIT & CONDUCTOR SCHEDULE PLAZA DE ARMAS		4	360	1760	640	6	4	1
TOTALS		1	17	360	6460	3245	22	14	3

include spec

ITEM		699.2	699.4	699.5	699.6
INTERSECTION		INSTALL FEDS FISH EYE CAMERA ASSEMBLY	LIFETIME FEDS DATA COLLECTION AND REPORTING	FEDS ETHERNET REPEATER	INSTALL FEDS COMMUNICATION CABLE (ETHERNET-CAT5E)
SHT NO		EA	EA	EA	LF
415	CONDUIT & CONDUCTOR SCHEDULE BUENA VISTA				190
423	POLE SCHEDULE & ILSN DETAILS PECOS-TRINIDAD	1	1	1	150
427	CONDUIT & CONDUCTOR SCHEDULE SAN SABA				
434	CONDUIT & CONDUCTOR SCHEDULE DOLOROSA / S SANTA ROSA				
441	CONDUIT & CONDUCTOR SCHEDULE PLAZA DE ARMAS	1	1	1	240
TOTALS		3	3	3	580

REV. NO.	DATE	DESCRIPTION	BY

PAPE-DAWSON ENGINEERS
 SAN ANTONIO | AUSTIN | HOUSTON | FORT WORTH | DALLAS
 2000 NW LOOP 410 | SAN ANTONIO, TX 78213 | 210.375.9000
 TEXAS ENGINEERING FIRM #470 | TEXAS SURVEYING FIRM #10028800

CITY OF SAN ANTONIO PUBLIC WORKS DEPARTMENT

DOLOROSA
TRAFFIC SIGNAL QUANTITY SUMMARY



SHEET 2 OF 2

DESIGN	CHECKED	DRAWN	PROJECT NO.	SUBMITTAL	SHEET NO.
ST	JT	JG	23-03763	70%	31

ITEM	531 SUP 01	531 SUP 02	531.03	531.05	531.06	531.07	531.11	531.18	531.19	531.21	531.22	531.51	531.57	531.62	531.68
SIGNING & PAVEMENT MARKINGS	SMALL SIGN ASSEMBLY	REMOVE SMALL SIGN ASSEMBLY	R1-1 STOP (30") (HIGH INTENSITY)	R1-5 STOP HERE TO PEDESTRIANS (30"x30") (HIGH INTENSITY)	R2-1 SPEED LIMIT (24"x30") (HIGH INTENSITY)	R3-1b EXCEPT BUSES (24"x24") (HIGH INTENSITY)	R3-5 RIGHT ONLY (30"x36") (HIGH INTENSITY)	R5-1 DO NOT ENTER (30"x30") (HIGH INTENSITY)	R6-1 ONE WAY (36"x12") (HIGH INTENSITY)	R7-1 NO PARKING ANYTIME (18"x24") (HIGH INTENSITY)	R7-6 NO PARKING LOADING ZONE (18"x24") (HIGH INTENSITY)	W11-2 PED CROSSING (30"x30") (HIGH INTENSITY)	9 INCH (229 MM) STREET NAME, BLOCK NUMBER (VARIES X 9") (HIGH DENSITY)	W16-9P AHEAD (36"x20") (HIGH INTENSITY)	R3-17 (BIKE LANE) (30"x24") (HIGH INTENSITY)
	EA	EA	EA	EA	EA	EA	EA	EA	EA	EA	EA	EA	EA	EA	EA
SIGNING & PAVEMENT MARKING LAYOUTS (SHEET 1 OF 5)	2	2								1					
SIGNING & PAVEMENT MARKING LAYOUTS (SHEET 2 OF 5)	11	9	1		2				2		1	2	2		
SIGNING & PAVEMENT MARKING LAYOUTS (SHEET 3 OF 5)	6	15							2		1	2		2	
SIGNING & PAVEMENT MARKING LAYOUTS (SHEET 4 OF 5)	9	16	1	2				2				2	2	2	2
SIGNING & PAVEMENT MARKING LAYOUTS (SHEET 5 OF 5)	2					1	1								1
PROJECT TOTAL	30	42	2	2	2	1	1	2	4	1	2	6	4	4	3

ITEM	531.70	531.72	535.1	535.2	535.4	535.7	535.12	535.13	535.16	535.17	535.26	535.27	535.28	537.9	658-6083	6999-6001
SIGNING & PAVEMENT MARKINGS	R3-17b (ENDS) (30"x12") (HIGH INTENSITY)	R1-2 (YIELD) (18"x18"x18") (HIGH INTENSITY)	4 INCH WIDE YELLOW LINE	4 INCH WIDE WHITE LINE	8 INCH WIDE WHITE LINE	24 INCH WIDE WHITE LINE	WHITE WORD	STRAIGHT WHITE ARROW	STRAIGHT WHITE ARROW BICYCLE FACILITY	BICYCLE RIDER SYMBOL	4 INCH WIDE BLACK LINE	SPECIAL BIKE WAIT AREA PAVEMENT MARKING	12 INCH WIDE BLACK LINE	PAVEMENT MARKER (TYPE II C-R)	INSTALL OM ASSM (D-SW) (WFLX) SRF	GREEN HIGH FRICTION SURFACE TREATMENT
	EA	EA	LF	LF	LF	LF	EA	EA	EA	EA	LF	EA	LF	EA	EA	SF
SIGNING & PAVEMENT MARKING LAYOUTS (SHEET 1 OF 5)		1	37	660	584	44		2	1	1	660	3		64		891
SIGNING & PAVEMENT MARKING LAYOUTS (SHEET 2 OF 5)			747	360	464	51		2	4	4	340	4		36		424
SIGNING & PAVEMENT MARKING LAYOUTS (SHEET 3 OF 5)			127	676	272	23			3	3	300	2		30	1	881
SIGNING & PAVEMENT MARKING LAYOUTS (SHEET 4 OF 5)			136	517	1281	129			6	6	360	1	80	34	27	160
SIGNING & PAVEMENT MARKING LAYOUTS (SHEET 5 OF 5)	1		50	50	864	57	3		1	1	50	1		15	12	220
PROJECT TOTAL	1	1	1097	2263	3465	304	3	4	15	15	1710	11	80	179	40	2576



Distinguish between COSA items and TXDOT items

REV. NO.	DATE	DESCRIPTION	BY
CAMACHO-HERNANDEZ & ASSOCIATES, LLC 415 EMBASSY OAKS - SUITE 205 SAN ANTONIO, TX. 78216 OFFICE: (210) 341-6200 FAX: (210) 341-6300 FIRM NUMBER: F-8478			
 PAPE-DAWSON ENGINEERS SAN ANTONIO AUSTIN HOUSTON FORT WORTH DALLAS 2000 NW LOOP 410 SAN ANTONIO, TX 78213 210.375.9000 TEXAS ENGINEERING FIRM #470 TEXAS SURVEYING FIRM #10028800			
 CITY OF SAN ANTONIO PUBLIC WORKS DEPARTMENT			
DOLOROSA SIGNING & PAVEMENT MARKINGS QUANTITY SUMMARY			
SHEET 1 OF 1			
DESIGN	CHECKED	DRAWN	PROJECT NO.
MGR	JH	HR	23-03763
SUBMITTAL		SHEET NO.	
70%		32	

CONDUIT QUANTITY SUMMARY

SHT NO	ITEM CONDUIT	618.3	618.6	624.1
		CONDUIT 4" PVC SCH 40 LF	CONDUIT 4" PVC SCH 40 (BORE) LF	GROUND BOXES (24"x36" POLYMER CONC) EA
491	CONDUIT LAYOUT	392		
492	CONDUIT LAYOUT	3170		5
493	CONDUIT LAYOUT	2870		2
494	CONDUIT LAYOUT	1562	900	4
495	CONDUIT LAYOUT	1804	504	2
496	CONDUIT LAYOUT	2414	296	4
497	CONDUIT LAYOUT	622		3
498	CONDUIT LAYOUT	652		2
TOTALS		13486	1700	22

Separate COSA-ITSD & UTSA quantities.

REV. NO.	DATE	DESCRIPTION	BY
 PAPE-DAWSON ENGINEERS <small>SAN ANTONIO AUSTIN HOUSTON FORT WORTH DALLAS 2000 NW LOOP 410 SAN ANTONIO, TX 78213 210.375.9000 TEXAS ENGINEERING FIRM #470 TEXAS SURVEYING FIRM #10028800</small>			
 CITY OF SAN ANTONIO PUBLIC WORKS DEPARTMENT			
DOLOROSA CONDUIT QUANTITY SUMMARY			
DESIGN	CHECKED	DRAWN	PROJECT NO.
ST	JT	JG	23-03763
SUBMITTAL		SHEET NO.	
70%		33	